

**FUNDAMENTALS OF DIGITAL SIGNAL PROCESSING  
(AEIE 3104)**

**Time Allotted : 2½ hrs**

**Full Marks : 60**

*Figures out of the right margin indicate full marks.*

***Candidates are required to answer Group A and  
any 4 (four) from Group B to E, taking one from each group.***

***Candidates are required to give answer in their own words as far as practicable.***

**Group – A**

1. Answer any twelve:

**12 × 1 = 12**

*Choose the correct alternative for the following*

- (i) If  $F_s$  is sampling frequency then the relation between analog frequency  $F$  and digital frequency  $f$  is  
 (a)  $f = \frac{F}{2F_s}$       (b)  $f = \frac{F_s}{F}$       (c)  $f = \frac{F}{F_s}$       (d)  $f = \frac{2F}{F_s}$
- (ii) In a signal  $x(n)$ , if 'n' is replaced by  $\frac{n}{3}$ , then it is called,  
 (a) upsampling      (b) folded version  
 (c) downsampling      (d) shifted version
- (iii) The complex valued phase factor/ twiddle factor,  $W_N$  can be represented as,  
 (a)  $e^{-j2\pi n}$       (b)  $e^{-j\frac{2\pi}{n}}$       (c)  $e^{-j2\pi}$       (d)  $e^{-j2\pi kn}$
- (iv) The number of complex additions and multiplication in FFT are, respectively  
 (a)  $\frac{N}{2} \log_2 N$  and  $N \log_2 N$       (b)  $N \log_2 N$  and  $\frac{N}{2} \log_2 N$   
 (c)  $\frac{N}{2} \log_2 N$  and  $\frac{N}{2} \log_2 N$       (d)  $N \log_2 N$  and  $N \log_2 N$
- (v) The unnormalized transfer function of lowpass Butterworth filter is obtained from normalized transfer function by replacing  $s_n$  by,  
 (a)  $\frac{s_n}{\Omega_c}$       (b)  $s_n \Omega_c$       (c)  $\frac{s}{\Omega_c}$       (d)  $s \Omega_c$
- (vi) The poles of Butterworth transfer function symmetrically lie on a circle in s-plane with angular spacing  
 (a)  $\frac{\pi}{N}$       (b)  $\frac{\pi}{2N}$       (c)  $\frac{2\pi}{N}$       (d)  $\frac{\pi}{N^2}$
- (vii) In impulse invariant transformation the digital frequency  $\omega$  for a given analog frequency,  $\Omega$  is given by,  
 (a)  $\omega = \Omega T$       (b)  $\omega = \frac{\Omega}{T}$       (c)  $\omega = \frac{T}{\Omega}$       (d)  $\omega = \tan \Omega T$
- (viii) The linear phase realization is used in FIR systems in order to minimize,  
 (a) multipliers      (b) memory      (c) delays      (d) adders



5. (a) Find the output  $y(n)$  of a filter whose impulse response is  $h(n) = \{1,1,1\}$  and input signal is  $x(n) = \{3, -1,0,1,3,2,0,1,2,1\}$  using Overlap add method. [[CO3](Apply/IOCQ)]
- (b) For the  $x_1(n)$ ,  $x_2(n)$  and  $N$  given compute  $x_1(n) \otimes x_1(n)$   
 $x_1(n) = \delta(n) + \delta(n - 1) + \delta(n - 2)$ ;  
 $x_2(n) = 2\delta(n) - \delta(n - 1) + 2\delta(n - 2)$ ;  
and  $N = 3$ . [[CO3](Apply/IOCQ)]

**8 + 4 = 12**

### Group - D

6. (a) Distinguish between IIR and FIR filters. [[CO4](Understand/LOCQ)]
- (b) Given the specification  $\alpha_p = 1 \text{ dB}$ ,  $\alpha_s = 30 \text{ dB}$ ,  $\Omega_p = 200 \text{ rad/sec}$  and  $\Omega_s = 600 \text{ rad/sec}$ . Determine the order of the filter. [[CO4](Apply/IOCQ)]
- (c) Prove that  $\Omega_c = \frac{\Omega_p}{(10^{0.1\alpha_p-1})^{1/2N}} = \frac{\Omega_s}{(10^{0.1\alpha_s-1})^{1/2N}}$ . [[CO4](Analyze/IOCQ)]

**2 + 4 + 6 = 12**

7. (a) Design a Butterworth filter satisfying the constraints
- $$0.707 \leq |H(e^{j\omega})| \leq 1 \quad \text{for } 0 \leq \omega \leq \frac{\pi}{2}$$
- $$|H(e^{j\omega})| \leq 0.2 \quad \text{for } \frac{3\pi}{4} \leq \omega \leq \pi$$
- with  $T = 1 \text{ sec}$  using the bilinear transformation. Realize the filter using direct form II realization structure. [[CO5](Evaluate/HOCQ)]
- (b) Write the magnitude and phase function of FIR filter when impulse response is symmetric and  $N$  is odd. [[CO5](Remember/LOCQ)]

**(5 + 5) + 2 = 12**

### Group - E

8. (a) A multirate systems is shown below. Find the relation between  $x(n)$  and  $y(n)$ .

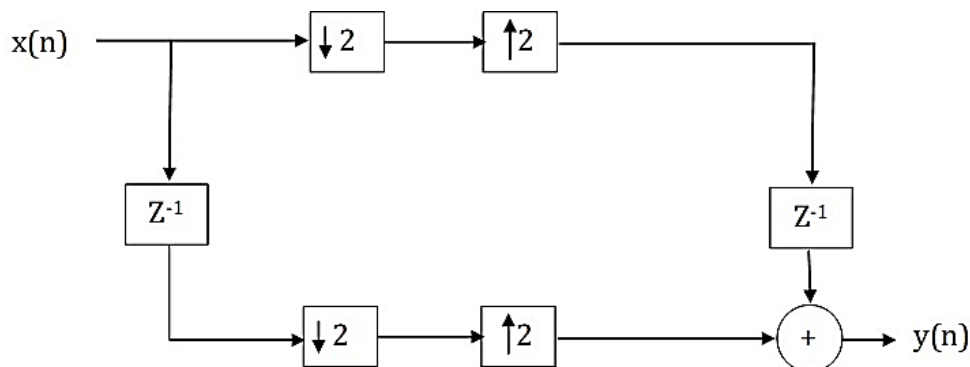

- (b) What is decimation and interpolation? [[CO6](Analyze/IOCQ)]
- (c) What is anti-aliasing filter? [[CO6](Remember/LOCQ)]

**6 + 4 + 2 = 12**

9. (a) What is multi-rate DSP? [[CO6](Remember/LOCQ)]

- (b) Give some examples of multirate digital systems. How different sampling rates are achieved in these types of systems? *[(CO6)(Remember/LOCQ)]*
- (c) Show that the up-sampler and down-sampler are time invariant system. *[(CO6)(Analyze/IOCQ)]*
- (d) What is decimator? Draw the symbolic representation of a decimator. *[(CO6)(Understand/LOCQ)]*

$$2 + (2 + 2) + 4 + 2 = 12$$

---

Cognition Level	LOCQ	IOCQ	HOCQ
Percentage distribution	18.75	70.83	10.41