

**PROJECT PLANNING AND MANAGEMENT
(CIVL 3214)**

Time Allotted : 3 hrs

Full Marks : 70

Figures out of the right margin indicate full marks.

Candidates are required to answer Group A and any 5 (five) from Group B to E, taking at least one from each group.

Candidates are required to give answer in their own words as far as practicable.

**Group - A
(Multiple Choice Type Questions)**

1. Choose the correct alternative for the following: **10 × 1 = 10**
- (i) Front open space for residential building up to 15.5 m height as per municipal building rule, is?
(a) 1.5 m (b) 1.2 m (c) 2.0 m (d) 1.8 m.
- (ii) Minimum width of stair in your college should be
(a) 1 m (b) 1.2 m (c) 1.5 m (d) 2 m.
- (iii) For any residential building if floor area is 2, and the plot size is up to 500 sq.m maximum permissible ground coverage should be
(a) 60% (b) 50% (c) 65% (d) 55%.
- (iv) When submitting a tender the contractor has to deposit a certain amount of money with the department as guarantee of the tender, the deposit is called
(a) security deposit (b) earnest money
(c) retention money (d) none of the above.
- (v) Someone who is appointed with or without mutual consent of owner and contractor for the purpose of investigation and settlement of the disputes is known as
(a) mediator (b) moderator (c) arbitrator (d) engineer.
- (vi) In critical path method, critical path is obtained by joining
(a) critical events (b) critical activities
(c) sub-critical events (d) sub-critical activities.
- (vii) The occurrence of the starting of an activity is called
(a) head event (b) tail event
(c) dual role event (d) predecessor event.

- (viii) For an activity, the optimistic time, most likely time and pessimistic time are 5 days, 7 days and 12 days respectively. The expected time is
(a) 6 days (b) 12 days (c) 7.5 days (d) 9.5 days.
- (ix) The amount of compensation payable by a contractor to the owner because of delayed construction is
(a) security deposit (b) retention money
(c) liquidated damage (d) unliquidated damage.
- (x) Target contract is of certain origin combining the merits of
(a) cost plus fixed fee contract (b) cost plus fluctuating fee contract
(c) all in contract (d) sub-contract.

Group - B

2. (a) A residential building is to be constructed on a plot area shown in Fig. 1. F.A.R. in 2 Maximum Ground Coverage is 50%. Determine the built-up area of the building. [(CO5)(Evaluate/HOCQ)]

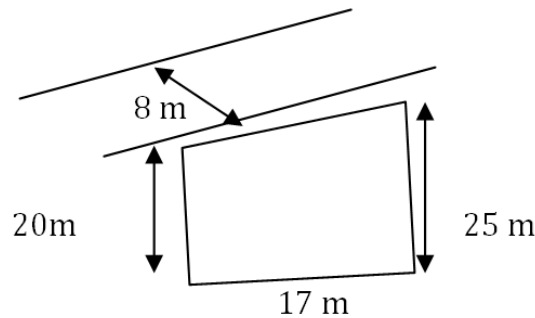

Fig. 1

- (b) Write short notes on:
(i) Carpet area and Ground Coverage
(ii) Circulation. [(CO5)(Understand/LOCQ)]
5 + 7 = 12
3. (a) A building has to be constructed on a plot area of 1000 sq.m. The site about two streets, one of 25 m width and another 15 m FAR is 2.0. If each storey contains 6 flats, determine the built up area of the building and its height. Ground coverage is maximum 52%. [(CO5)(Evaluate/HOCQ)]
(b) What are the basic requirements of building planning? [(CO5)(Understand/LOCQ)]
7 + 5 = 12

Group - C

4. (a) Calculate the time required to grade and finish 30 km of road formation of 9.0 m width for two lane road with motor grader having width of 3.0 m, using 6 passes with speed for each of the successive two passes at 5 kmph, 7 kmph and 9 kmph respectively. Assume machine efficiency based on operator skill, machine characteristics and working conditions as 80%. [(CO4)(Evaluate/HOCQ)]

(b) Describe with a diagram power shovel. What are the factors affecting the output of power shovel. [[CO4](Understand/IOCQ)]

5 + 7 = 12

5. (a) A four wheel tractor weighing 1800 kg has weight distribution between the front and rear wheels of 40% and 60% respectively. It is operating on a level haul road whose rolling resistance is 45 kg per ton. What is the maximum effective rimpull of the tractor if the coefficient of traction between the road surface and the tire is 0.65? [[CO4](Evaluate/HOCQ)]

(b) Write short notes on Clamshell and Grader with their schematic diagram. [[CO4](Understand/LOCQ)]

5 + (3.5 + 3.5) = 12

Group - D

6. (a) What is a bar chart? What are the advantages and disadvantages of bar chart?

(b) Draw a bar chart Time (weeks) Vs Activity break down as follows:

Activities	Time (weeks)
A	0-3 Weeks
B	0-4 Weeks
C	5-7 Weeks
D	6-8 Weeks
E	10-12 Weeks
F	11-13 Weeks
G	13-16 Weeks

[[CO1](Evaluate/HOCQ)]

6 + 6 = 12

7. The time estimates in days are shown in the given network. Find out standard deviation for the network and critical path.

[[CO3](Evaluate/HOCQ)]

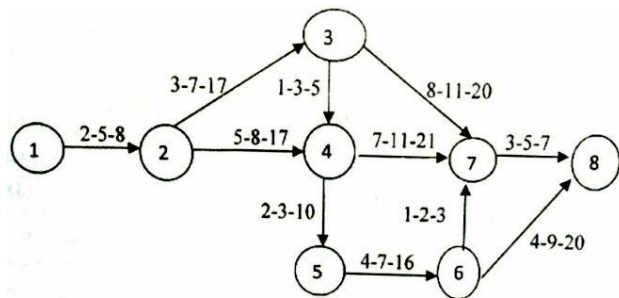

12

Group - E

8. (a) What is a contract? [[CO2](Understand/LOCQ)]

(b) Discuss any three types of contract in detail. [[CO2](Understand/IOCQ)]

4 + 8 = 12

9. (a) Distinguish between security deposit and retention money.

[[CO2](Analyse/IOCQ)]

- (b) What is arbitration? Discuss the need for arbitration. What are the wanted qualification of arbitrator?

[(CO6)(Understand/IOCQ)]

5 + (2 + 2 + 3) = 12

Cognition Level	LOCQ	IOCQ	HOCQ
Percentage distribution	23.96	28.12	47.92

Course Outcome (CO):

After the completion of the course students will be able to

1. Develop the bar chart for the project.
2. Compile the tender documents.
3. Estimate the critical path of the project i.e., the maximum duration which the project requires for completion.
4. Understand the uses of various construction equipments at site and the preparation of concrete.
5. Make use of the bylaws of different authorities to get the approval of drawings for construction.
6. Understand the process of arbitration in case the projects suffer from disputation.

*LOCQ: Lower Order Cognitive Question; IOCQ: Intermediate Order Cognitive Question; HOCQ: Higher Order Cognitive Question