

**DESIGN OF STEEL STRUCTURES
(CIVL 3201)**

Time Allotted : 3 hrs

Full Marks : 70

Figures out of the right margin indicate full marks.

Candidates are required to answer Group A and any 5 (five) from Group B to E, taking at least one from each group.

Candidates are required to give answer in their own words as far as practicable.

**Group - A
(Multiple Choice Type Questions)**

1. Choose the correct alternative for the following: **10 × 1 = 10**
- (i) The diameter of bolt hole can exceed the diameter of the bolt by about
(a) 1.5 to 2 mm (b) 1 to 3 mm
(c) 2 to 5 mm (d) >5 mm.
- (ii) The minimum edge distance in member with rolled edge is approximately
(a) 1.5x whole diameter (b) 1.7 x whole diameter
(c) 2x bolt diameter (d) 1.7x bolt diameter.
- (iii) Using welding, we can obtain up to
(a) 75% efficiency (b) 85% efficiency
(c) 95% efficiency (d) 100% efficiency.
- (iv) Which of the following is not a mode of failure in a tension member?
(a) Gross-section yielding (b) Net section rupture
(c) Local buckling (d) Block shear failure.
- (v) The deflection of steel beams in buildings other than industrial buildings and supporting elements susceptible to cracking is limited in IS 800 to span divided by
(a) 360 (b) 150 (c) 300 (d) 180.
- (vi) The design bending strength of a laterally unsupported beam is given by
(a) $\beta_b Z_p f_y / \gamma_{m0}$ (b) $\beta_b Z_p f_{bd} / \gamma_{m0}$
(c) $\beta_b Z_p f_{bd}$ (d) $Z_p f_{bd} / \gamma_{m0}$
- (vii) What is the buckling class of built - up members?
(a) a (b) b (c) c (d) d
- (viii) What horizontal surge force acts on the rails of a gantry girder due to applying brakes of the crab unit?
(a) 20 percent of weight of crab and the weight lifted by the cranes

- (b) 15 percent of weight of crab and the weight lifted by the cranes
- (c) 10 percent of weight of crab and the weight lifted by the cranes
- (d) 5 percent of weight of crab and the weight lifted by the cranes.

- (ix) Considering serviceability requirements, what is the limiting depth to thickness ratio (d/t_w) of a girder without any transverse stiffeners?
 - (a) 100ϵ
 - (b) 200ϵ
 - (c) 300ϵ
 - (d) 400ϵ .
- (x) What is the maximum outstand of stiffeners? t_q = Thickness of stiffeners.
 - (a) $20t_q\epsilon$
 - (b) $30t_q\epsilon$
 - (c) $40t_q\epsilon$
 - (d) $50t_q\epsilon$.

Group - B

- 2. (a) Two plates 10 mm × 60 mm are connected in a lap joint with 5 M16 bolts of grade 4.6 and 410 grade plates as shown in Fig.1. Calculate the strength of the joint.

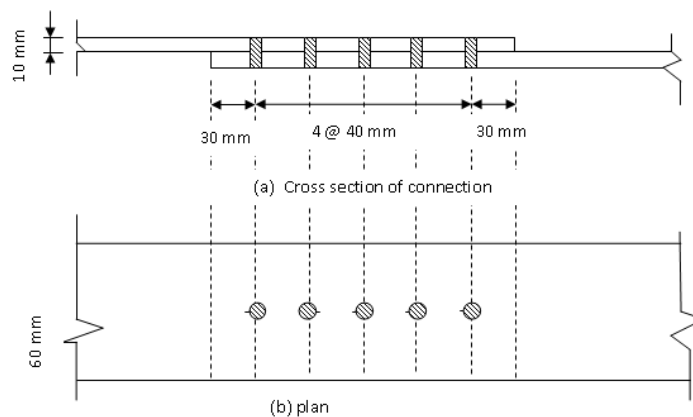

Fig.1

- (b) Determine the size of the bolts required to connect the bracket (supporting the gantry girder) to the column shown in Fig.2. Properties of ISMC 250 @ 299 N/m: $A_n = 3867\text{mm}^2$, depth of section $h = 250$ mm.

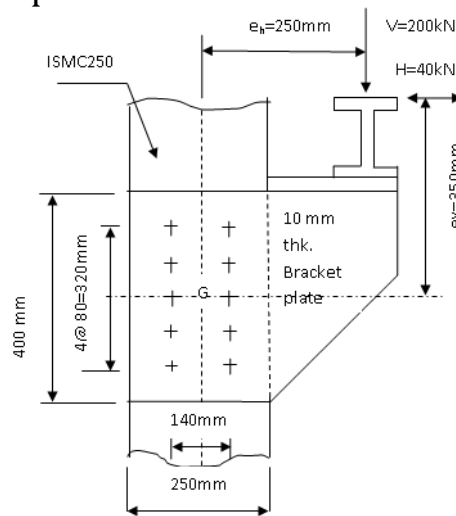

Fig. 2

6 + 6 = 12

- 3. (a) Design a connection to joint two plates of 200 × 10 mm of grade Fe 410 to mobilize full plate tensile strength using shop fillet welds if a double cover butt joint is used.

- (b) Determine the maximum load that could be resisted by the bracket shown in Fig.3, assume the plate thickness does not affect the result and if 6mm shop fillet welds are used.

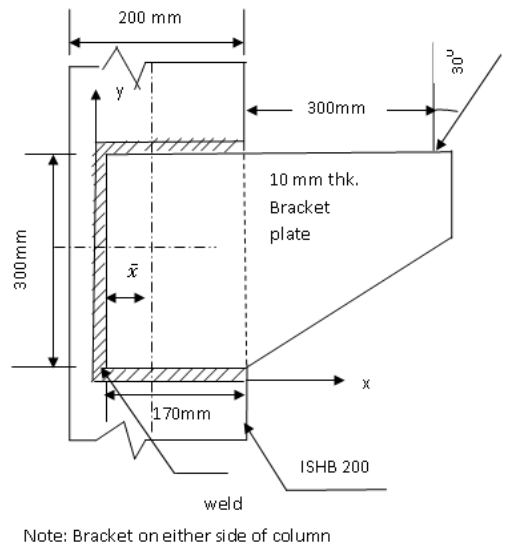

Fig.3

4 + 8 = 12

Group - C

4. Design a suitable angle section to carry a factored tensile force of 250 kN assuming a single row of M20 bolts. The yield strength and ultimate strength of the material is 250 Mpa and 410Mpa respectively. The length of the member is 3 m. Select an angle 75 × 75 × 8 with $A_g = 1138 \text{ mm}^2$, $r_{xx} = 22.8 \text{ mm}$ and $r_{yy} = 22.8 \text{ mm}$. The strength of 20 mm diameter bolts in single shear is 45.3 kN.

12

5. (a) Determine the design axial load on column section ISMB 500 @ 852N/m, height of column is 4m and it is pin-ended. Assume that $f_y = 250 \text{ N/mm}^2$, $f_u = 410 \text{ N/mm}^2$, $E = 2 \times 10^5 \text{ N/mm}^2$. Properties of the section: $A_n = 11074 \text{ mm}^2$, depth of section $h = 500 \text{ mm}$, width of flange $b_f = 180 \text{ mm}$, thickness of flange $t_f = 17.2 \text{ mm}$, thickness of web $t_w = 10.2$, radius of gyration $r_{zz} = 202.1 \text{ mm}$, $r_{yy} = 35.20 \text{ mm}$.

- (b) Design a gusseted base for a column ISHB 400 @ 806 N/m with two plates 500mm × 20mm carrying a factored load of 2600 kN. The column is to be supported on concrete pedestal with M20 grade concrete. Properties of ISHB 400 @ 806N/m $A = 104.66 \text{ mm}^2$, $h = 400 \text{ mm}$, $b_f = 250 \text{ mm}$, $t_f = 12.7 \text{ mm}$, $t_w = 10.6 \text{ mm}$, Assuming ISA 150 × 150 × 15 as shoe angle and 16 mm gusset plate. $\sigma_{cbc} = 9 \text{ MPa}$ for M20 concrete. Use 20mm diameter shop bolts with strength in single shear 45.27 kN.

4 + 8 = 12

Group - D

6. Calculate the moment capacity of a laterally supported beam made of ISMB 350 @ 52.4 kg/m under applied factored shear 300kN. Consider $f_y = 250 \text{ N/mm}^2$, $f_u = 410 \text{ N/mm}^2$, $E = 2 \times 10^5 \text{ N/mm}^2$. The properties of ISMB 350 @ 52.4 kg/m are given as follows: sectional area (A) of I – section = 66.71 cm², $I_{xx} = 13630.3 \text{ cm}^4$, $I_{yy} = 537.7 \text{ cm}^4$, width of

B.TECH/CE/6TH SEM/CIVL 3201 (BACKLOG)/2021

flange (b_f) = 140 mm, thickness of flange (t_f) = 14.2 mm, thickness of web (t_w) = 8.1 mm, radii of Gyration (r_{zz}) = 14.32 cm, (r_{yy}) = 2.84 cm, Section Modulus (Z_{ez}) = 779.0 cm³, Plastic modulus (Z_{pz}) = 889.57 cm³, Radius at root(r_1) = 14mm.

12

7. Determine the moment and shear capacities of a plate girder having 460 mm × 30 mm flange plate at top, 1100 mm × 15 mm web plate and 460 mm × 30 mm flange plate at the bottom. Consider $f_y = 250$ N/mm², $f_u = 410$ N/mm² and Simple Post Critical method. Calculate buckling resistance of web also.

12

Group – E

8. A gantry girder, without lateral restraint along its span, to be used in an industrial building carrying an overhead travelling crane for the following data.
Centre-to-centre distance between columns (i.e. span of gantry girder) = 8 m
Crane capacity = 220 kN
Self-weight of the crane girder excluding trolley = 200 kN
Self-weight of trolley, electrical motor, hook etc. = 45kN
Minimum hook approach = 1.3 m
Distance between wheel centres = 3.5 m
Centre-to-centre distance between gantry rails (i.e., span of the crane) = 16 m
Self weight of the rail section = 300 N/m
Yield stress of steel = 250MPa. Calculate the maximum bending moment and shear force on the girder.

12

9. A welded gantry girder, without lateral restraint along its span, to be used in an industrial building carrying an overhead travelling crane is fabricated using ISMB 450 @ 72.4 kg/m with a ISMC 225 @ 25.9 kg/m at the top. Centre-to-centre distance between columns (i.e. span of gantry girder) =8 m. Calculate the moment capacity of the gantry girder. Consider $f_y = 250$ N/mm², $f_u = 410$ N/mm², $E = 2 \times 10^5$ N/mm².
The properties of ISMB 450 @ 72.4 kg/m are given as follows:
sectional area (a) of I – section = 92.27 cm², $I_{xx} = 30390.8$ cm⁴, $I_{yy} = 834.0$ cm⁴, width of flange (b_f) = 150 mm, thickness of flange (t_f) = 17.4 mm, thickness of web (t_w) = 9.4 mm, Radii of Gyration (r_{zz}) = 18.15 cm, (r_{yy}) = 3.01 cm, Section Modulus (Z_{ez}) = 1350.7 cm³, Plastic modulus (Z_{pz}) = 1533.36 cm³.
The properties of ISMC 225 @ 25.9 kg/m are given as follows:
Sectional area (a) = 33.01 cm², Depth of section (h) = 225 mm, Width of flange (b) =80mm, Thickness of flange (t_f) =12.4 mm, Thickness of web (t_w) = 6.4 mm, Radii of Gyration (r_{zz}) = 9.03cm, (r_{yy}) = 2.38cm, Moment of inertia (I_{zz}) = 2694.6 cm⁴, Moment of inertia (I_{yy}) = 187.2cm⁴, $C_{yy} = 23$ mm.

12

Department & Section	Google classroom joining code	Submission Link
CE	ns4c4fx	https://classroom.google.com/w/MzY0NDIOMjQzNjg3/t/all