

Welcome To The  
Post-Covid World

2021  
Loading

Musk Continues To Ride  
High With Tesla-SpaceX

₹125

VOL. 33 | ISSUE 12 | DECEMBER 2020

www.pcquest.com

# PCQUEST

UNDERSTAND • CHOOSE • IMPLEMENT IT

How To  
Buy The  
Greatest  
Gadgets  
For Your  
New Year



# COVID-19 & TECH 2020

*We are already living in an upgraded New Normal*



# SAMSUNG

## 970 EVO Plus



### Unreal performance realised



Faster performance

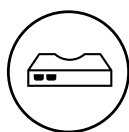

Exceptional endurance

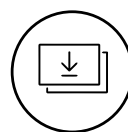

Samsung Magician software



Scan to experience

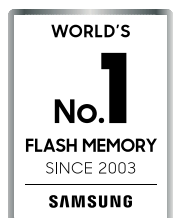

Available at: Amazon | Flipkart · Follow us on: [facebook.com/SamsungSSD/](https://facebook.com/SamsungSSD/) | [instagram.com/samsungmemory/](https://instagram.com/samsungmemory/)

Please dispose of e-waste and plastic waste responsibly. For more information or for e-waste pick up, please call 1800 30 SAMSUNG (7267864) or 1800 5 SAMSUNG (7267864).

Source: 2003 - 2020 IHS Markit data: NAND suppliers' revenue market share.

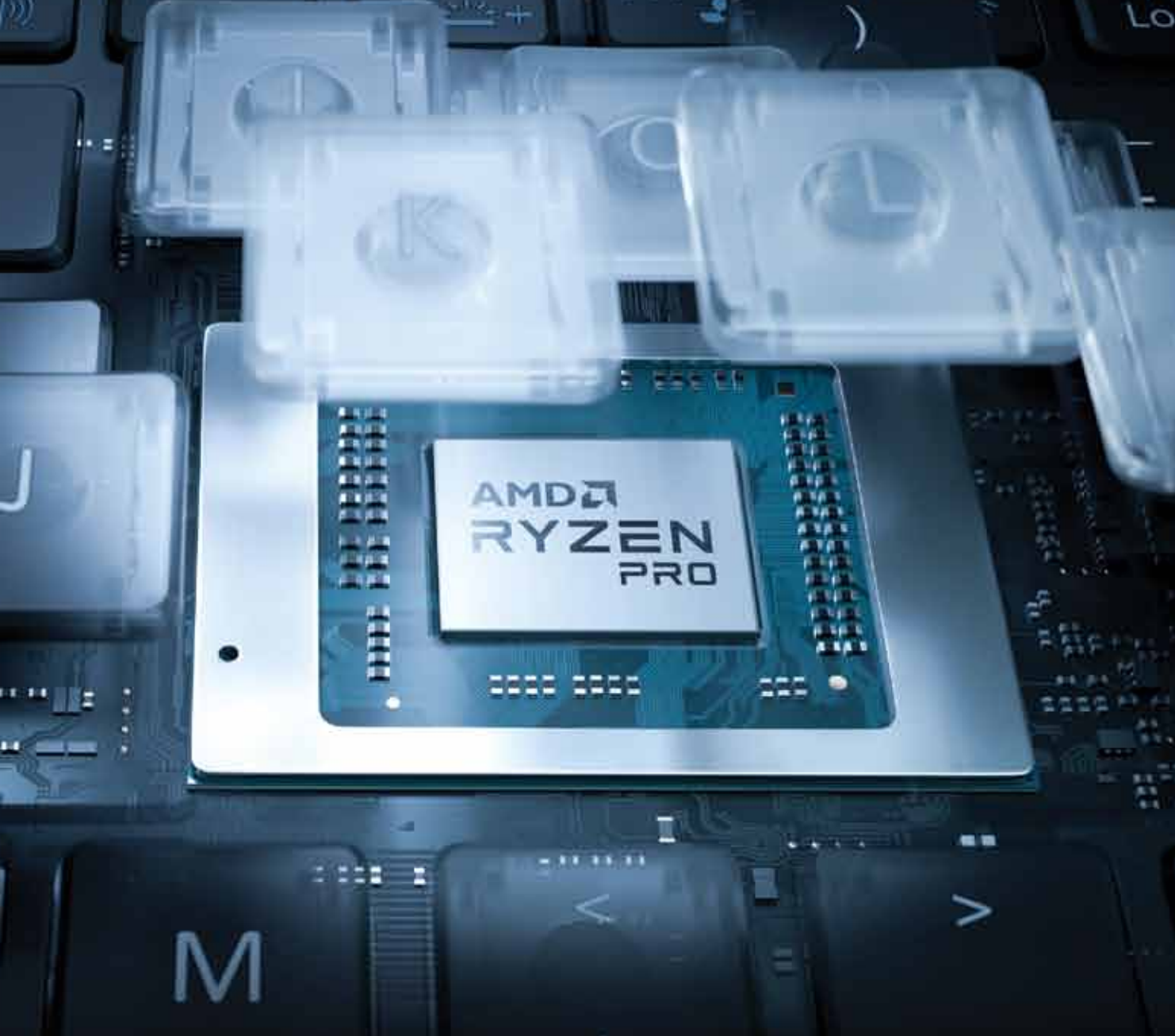

## Pure performance under the lid

Upgrade to the world's fastest processor for ultrathin laptops featuring AMD PRO technologies. Designed for business.

**AMD**  
**RYZEN**  
**PRO**



# Contents

**8-18 COVER STORY — YEARENDER**

## **P8 A GREAT YEAR FOR TECHNOLOGY**



While the Covid-19 pandemic-lockdown-recession was really tragic, the real silver lining was the way technology stood up, accelerated and filled in the vacuum so that mankind could not only cope, but look forward to boot. We are entering a brand new era which we are still struggling to define and predict what it will actually be like. Terms like “New Normal” and “Post-Covid” have entered the popular lexicon

## **P16 THE A TO Z OF 2020**



A year of momentous upheaval where the Covid crisis took everyone by storm, the lockdown led to great technology innovations and Big Tech continued to flourish amid the recession

# DECEMBER 2020

## PEOPLE OF THE YEAR

**20 Musk Continues To Ride High**

## TECH TRENDS 2021

**24 Welcome To The Post-Covid World**



## BUYING GUIDE

- 44 How To Choose A Tablet For Students?**
- 46 How To Choose The Right Smartphone**
- 52 How To Choose The Right Printer?**
- 57 Everything You Need To Know Before Buying The Best Speaker**

## AUTOMATION

**68 Take Your Shared Service Centre to the Next Level with Automation**



**70 COVID-19: The Trigger For Creating A Hybrid Workforce**

## SECURITY

**63 Cyber Security Job Roles To Watch Out For In 2021**



## CLOUD

**65 A Goldmine That's Waiting For Columbus, Not For Midas**



## REVIEW

**73 Synology Diskstation DS920+**



**74 Viewsonic VX3258-2KC-MHD Monitor**



## SUBSCRIBE NOW!



Turn to page 42

# PCQUEST

UNDERSTAND • CHOOSE • IMPLEMENT IT

## EDITORIAL

**MANAGING EDITOR:** Thomas George  
**EDITOR:** Sunil Rajguru  
**ASSOCIATE EDITOR:** Soma Tah  
**ASSISTANT EDITOR:** Supriya Rao  
**EDITORIAL SUPPORT:** Archana Verma  
**CONSULTING EDITOR:** Anusha Ashwin  
**ASSISTANT EDITOR (Special Projects):** Ankit Parashar  
**CORRESPONDENT:** Aanchal Ghatak  
**DESIGN MANAGER:** Nadeem Anees

**VICE PRESIDENT RESEARCH:** ANIL CHOPRA

## CYBERMEDIA LABS

**MANAGER LAB:** Ashok Pandey

## BUSINESS

**SR. VICE PRESIDENT:** Rachna Garga (rachnag@cybermedia.co.in)

### NORTH:

**ASSOCIATE VICE PRESIDENT:** Harminder Singh  
**MANAGER:** Sudhir Kumar Arora, Mohammad Shoeb Khan

### SOUTH:

**MANAGER:** Shubhadeep Sen

### WEST:

**MANAGER:** Shubhadeep Sen

### EAST:

**MANAGER:** Sudhir Kumar Arora

**MARKETING & ALLIANCES** (marketing@cybermedia.co.in)

**SR. VICE PRESIDENT:** Rachna Garga  
**MANAGER MARKETING:** Rajiv Pathak  
**MANAGER, MIS & DATABASE:** Ravi Kant Kumar

## OPERATIONS

**GENERAL MANAGER:** CP Kalra  
**MANAGER:** Ashok K

## EVENTS & COMMUNITIES

**SENIOR MANAGER:** Debabrata T Joshi  
**ASST. MANAGER:** Shiv Kumar

## CIRCULATION & SUBSCRIPTIONS

**HEAD:** Rachna Garga  
**SR. MANAGER:** Sarita Shridhar  
**SR. PRESS CO-ORDINATOR:** Harak Singh Ramola  
**CHENNAI:** C Ramachandran

**For subscription queries contact:** rsepcq@cybermedia.co.in

**Send all your tech questions to:** pcquest@cybermedia.co.in

## CORPORATE OFFICE

**Cyber House, B-35, Sec-32, Gurugram (NCR Delhi) 122001, India**  
**email us** pcquest@cybermedia.co.in  
**call us** +91-124-482-2222, **fax us** +91-124-238-0694

## OUR OFFICES

### BENGALURU

**Address:** 205-207, Sree Complex (Opp. RBNMS Ground)  
# 73, St John's Road, Bangaluru - 560 042  
Tel: +91 (80) 4341 2000, Fax: +91 (80) 2350 7971

### MUMBAI

**Address:** 404 Trade Square, Mehra Industries Compound Safed Pool,  
Sakinaka, Andheri East, Mumbai - 400072  
Mobile: 9969424024

### DELHI

**Address:** Cyber House, B-35, Sec 32, Gurugram,  
NCR Delhi-122001. Tel: 0124-4822222, Fax: 2380694

**Printed and published** by Pradeep Gupta on behalf of CyberMedia (India) Ltd, printed at printed at M/s Archna Printers, D-127, Okhla Industrial Area, Phase-1, New Delhi, published from D-74, Panchsheel Enclave, New Delhi-110017. Editor: Sunil Rajguru. Distributed in India by IBH Books & Magazines Dist. Pvt. Ltd, Mumbai. All rights reserved. No part of this publication may be reproduced by any means without prior permission.



[www.pcquest.com](http://www.pcquest.com)



<http://twitter.com/pcquest>



<http://facebook.com/pcquest>



<http://linkedin.in/pcquest>



<http://gplus.to/pcquest>



[pcquest@cybermedia.co.in](mailto:pcquest@cybermedia.co.in)



Sunil Rajguru, Editor  
sunilr@cybermedia.co.in

## Tech for the marginalized

The big corporations have all the money and resources to use cutting edge technology. The middle class also uses tech well. This has been further accelerated by the Covid crisis. However the next thrust to push technology should be for the benefit of the rural masses, the small industries along with the poor and marginalized. The biggest roadblock we had when we entered the 2010s was erratic electricity for the top half of the populace and none to miniscule access to power for the lower half. That has been by and large sorted out. We are on course for complete electrification of India in a few years from now.

The second problem was access. The poor and rural masses had limited access to things like bank accounts and government offices which they dreaded. This has been sorted out with the mobile being the ultimate access device. It has achieved deep penetration, something which the desktop and laptop failed to do in the last couple of decades. The mobile can be linked with Aadhaar and serve as an identification device. Things like contact tracing have ensured further integration within the government system. While the Jan Dhan Yojana (the final inclusion government scheme including banking) has been really successful, online money has brought in even those who did not benefit from it into the fold. The mobile can prove to be the biggest e-governance tool for the marginalized and rural masses. The government can make its entire strategy out of that alone.

After that the biggest area is agritech, which has a huge potential. By some estimates, it can increase by hundredfold in the 2020s which sounds great but also shows you how much it has been underutilized in the first place. The farmer can link his mobile to IoT devices in tractors and pumps to get a local ecosystem which he can monitor regularly. The government can go in for a brand new digital agri-ecosystem which all farmers can be part of. The infrastructure is finally there and all that is required is a comprehensive plan followed by implementation.

Finally the biggest sufferers of the Covid crisis were the small and medium enterprises. They don't have a solid and reliable business continuity planning but Industry 4.0 is a great counter for that, especially if it can be implemented at an affordable rate. There are enough tools related to automation, the cloud and SaaS offerings that can see them through for both productivity and business continuity.

“Last mile connectivity for Deep Tech” could be a good mantra that would see the most marginalized through the 2020s via a long needed upgrade.

*Sunil Rajguru*

“  
**Focus on last mile  
connectivity**  
”

# A GREAT YEAR FOR TECHNOLOGY

While the Covid-19 pandemic-lockdown-recession was really tragic, the real silver lining was the way technology stood up, accelerated and filled in the vacuum so that mankind could not only cope, but look forward to boot. We are entering a brand new era which we are still struggling to define and predict what it will actually be like. Terms like “New Normal” and “Post-Covid” have entered the popular lexicon

Sunil Rajguru  
sunilr@cybermedia.co.in



We correctly called it at the very beginning of the year with our January PCQ cover story. “Technological Acceleration”, “Digital Acceleration” and “Rapid Digitization” were indeed the key themes of 2020.



**P**andemic I: 20-50 million may have been killed in the Spanish Flu of 1918. The upper estimate has been put at 100 million. This is alarming and shocking even more so when you realize that the global population at that time was well under 2 billion. Today we are racing toward 8 billion. Millions died in India too at that time, where it was called Bombay Fever. The infection may have come from US sailors visiting Bombay.

If there is one thing clear at that time—We were woefully short on both medical technology to fight and cope and even general technology to adjust to a lifestyle change. There could be no collaboration—There were limits to what you could do with the telephone and telegraph. You couldn't Work From Home—That old economy totally depended on everyone going to their farms, factories or offices. The globe just had to let the curve flatten itself without being able to manipulate it too much.

**Technological Acceleration I:** World War I (1914-18) was followed by the Spanish Flu (1918-20). After that we had the Great Depression (1929-late 1930s). If that wasn't enough, all that was followed by the Holocaust and World War II (1939-45). If there's only one thing that saved the world, it was the rapid technological acceleration that took place in this time period that was unparalleled in history.



The Germans invented the jet engine which was adopted by the whole world and it ushered in an era of air travel. But the biggest advances they made were in the field of rocketry. That kick started the Space Age and the formation of NASA. The greatest offshoot of that was the Satellite Revolution which enabled the likes of satellite TV, GPS and other advances in communication, weather and astronomy.

The Allied Forces countered the Axis Powers with technological breakthroughs of their own. When the Germans started jamming all the frequencies of the British transmissions, they came out with Code Division Multiple Access to counter it. Later CDMA was an integral part of the mobile broadband story. The Germans came out with the Enigma machine. It was a great feat which was countered by the British with immense feats of code breaking. They made great advances in cryptography that serve us to this present day in the Internet Age. The Colossus Computer that they created preceded ENIAC and has been called "the world's first programmable, electronic, digital computer". In a way, that's where you could say the Computer Revolution actually began.

While Hiroshima and Nagasaki were great tragedies, there have been no nuclear attacks since then thankfully. One offshoot of that research was atomic energy. That could be the key to the future if we want to get off fossil fuels because so far the combination of solar, wind and hydrogen is woefully short. Today startups are trying to promote Generation IV nuclear plants which are safer and more compact than the current outdated ones. Some can even use nuclear waste as fuel, making it a rich closed energy cycle. One of the big promoters of that is Microsoft founder Bill Gates.

There is a myth that Charles Holland Duell, the Commissioner of the United States Patent Office (1898 to 1901), declared at the beginning of the twentieth century, "Everything that can be invented has been invented." If he actually said that, then it would be one of the most failed predictions in history. The way Gates is supposed to have declared grandly in 1981, "640KB of memory ought to be enough for anybody". But it seems there is no basis for the quotes of either Duell or Gates. (Gates is also at the forefront of pandemic prediction and suggesting healthcare solutions.)

Duell in fact is supposed to have said, "In my opinion, all previous advances in the various lines of invention will appear totally insignificant when compared with those which the present century will

witness. I almost wish that I might live my life over again to see the wonders which are at the threshold." If that's the case, then he was spot on!

**Singularity I:** There is a popular concept in Silicon



Valley called the Singularity. It refers to the time when humankind could merge with Artificial Intelligence. It is also called the Technological Singularity. The 2010s was the greatest step in that direction with the proliferation of the smartphone.

Earlier there was no invention which you used to be with 24X7. During the industrial revolution, workers would go home after spending the day at the factory. The same was with the work computer. You shut off your home workstation and laptop. But your smartphone is with you 24X7 and is an extension of your personality. You take it wherever you go. You use it in the bathroom and sleep with it. You feel lost without it. It is your comfort device. It's both your library and book. It knows where you are at all times and helps you around anywhere in the world and hails your cab.

You can book tickets or order your meals and groceries. It is both for work and pleasure. It's your road to communicating with everyone in the world and your social life thanks to the many social networks it is part of. It's your jukebox, TV set and cinema hall. If you're part of the mobile workforce, then it's your office too and a handy video collaboration device. In a way you are like a cyborg integrated with your mobile. One sociologist called this the greatest lifestyle change for humanity since the end of World War II.

**Sequel to all of the above:** Covid probably merged all the above concepts. We had another pandemic, further digital acceleration and came closer to and became dependent on technology like

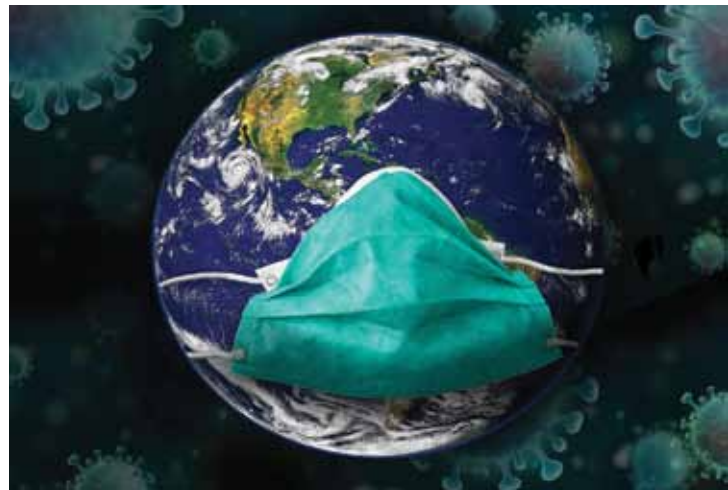

never before. Many of the things that have happened are irreversible. The 2020s New Normal will be totally different from the hypothetical 2020s Normal that would have happened had there been no Covid in the first place.

Last time during the Spanish Flu we were totally off guard and the upper estimate put the human loss at a whopping 5% plus of the global population. This time while we seem to have been caught off-guard, we had much greater tech tools than last time. The death toll is in the region of 1.5 million. While every life is important, you have to note that this time the death toll has been 0.02% of the global population. Did we get such a low rate because of all the tech tools we had for healthcare and social distancing? We shall never know, but that's food for thought.

The global healthcare industry has seen a fillip. For one telemedicine may now be promoted with the need for social distancing and the rise of collaboration and bandwidth. This will be quite useful for a first consultation where the doctor screens out the serious and non-serious cases and can sort out the mild cases easily. Ecommerce for medicines also saw an upswing and that will also be handy for remote areas where a medical shop isn't nearby.

The use of Big Data analytics and AI may also go up in the medical field. Of course, privacy will be a huge issue here. Wearable IoT devices that transmit the health of the user may also increase, as this is favoured by insurance companies. The use of robots is already seeing a spike in Western hospitals. Could we also have more robotic surgeries? Nanotechnology is one field that is beneficial for things like vaccines and PPEs (Personal Protective Equipment).

**Superfast vaccines:** The vaccine story during Covid has been spectacular. Past vaccines used to take years and sometimes even decades to



make. Indeed smallpox and polio had been around for thousands of years and some vaccines took hundreds of years to develop. Covid-19 came at the end of 2019, the vaccines went through the entire developmental phase and are ready for release by 2020-end. That's lightning fast in the world of medicine.

Nowadays these vaccines are designed on the computer and can be replicated on a machine. If found successful: They can be put into mass production at once. The messenger RNA vaccine was conceptualized in the middle of the last century and earnest research began in the 1990s. But no mRNA vaccine was given clearance till now—but here we are ready for release. There were hundreds of vaccine trials and just one of them—Pfizer—is ready to vaccinate 1.3 billion by the end of 2021. These are unheard of numbers made possible thanks to technology. The Government of India is pushing States to start working on a cold storage network to accommodate vaccines, but such a network will be beneficial for many other things too. But will they work? That is the billion dollar question and that could boost or sink this new industry

What about the next pandemic? How will we handle that? I had written in an editorial some time back: In the future, facial recognition systems across airports and other public places will report a sudden spike in people suddenly sneezing or coughing. Based on that an AI system will personally alert every such mobile user and also warn the healthcare industry. Based on the change in patient symptoms across the world, governments will be alerted that a global pandemic is on the way.

AI will check the geographical densities of cases and recommend a lockdown timetable for each and every part of the world. Drones and driverless cars

will press into action to ensure essential services and supplies. The global network of IoT devices will give real-time information on the status of goods, supplies and movement of humans. AI will track everything at a micro and macro level modifying its recommendations repeatedly. When the curve has been flattened, an AI timetable will bring the world back to normal.

**Smart Work From Home:** The first industry that



really took off in 2020 was collaboration. The thing is, it wasn't just Zoom. A multitude of collaboration tools proliferated and more importantly the global bandwidth was upped suddenly. Companies maximized their use for official purposes while we saw a lot of first time users for personal use.

It wasn't just about video collaboration. They facilitated official calls, strategy meets and the exchange of important files and data. Webinars, virtual conferences and video round tables filled in the void left by physical meetings and conferences. Going forward 3D and VR collaboration could be an emerging market that could become quite big.

In conjunction with this the global real estate industry is seeing a huge change. The Smart Home and WFH culture will now emerge to become SWFH. In the past Smart Homes used to be for the rich, but with the proliferation of devices like Alexa and Google Home, they can be the cornerstone of a Smart Home quite easily for the middle class. The Amazon Ring is an external doorbell with a camera that can monitor the outside of a home and even alert the police. It has an indoor version and one with a home drone plus one for the car too.

The coronavirus was discovered in the 1920s, but

it was only in 2003 that it became a serious threat with SARS and we had MERS in 2012. Covid-19 is in fact SARS-2 and we will probably have to be on our guard permanently from now on. That means with threats and lockdowns, temporary WFHs could become a regular affair. Of course there's also the fact that many jobs have become permanently WFHed. The exact numbers will be clear for a couple of years. The construction of flats and independent houses will see a sea change and integration of the office functionality will become a regular affair.

**Expansion of ecommerce:** Certain geographies



have seen growth in the region of 40-50% in ecommerce sales and there has been a sharp rise in its penetration. Getting first time users on board used to be the biggest issue but that happened seamlessly in 2020. Ecommerce initially struggled to cope with the load, but now there has been an upgrade which will fuel growth in the 2020s.

**Mobile workforce:** The regular office space, the SWFH and mobile workforce will now form the trifecta of the New Economy. The smartphone is getting greater compute power and apps that can make it do anything a laptop or desktop can. We also have mobile SaaS. Once storage used to be an issue, but thanks to the cloud and rising mobile broadband capability, that is no longer so. The mobile workforce can include things like iPads and in the future wearable IoT devices too.

There can be many advantages. There is no need for real estate for the mobile workforce; it can ensure business continuity, better operational costs and faster resolution times for the customers, especially enhancing last-mile service. It has proved handy in industries like retail, healthcare, insurance, manufacturing, construction etc. In the Covid



collaboration era, WhatsApp had to increase video calls from 4 to 8 people.

**Rise of online education:** Said Scott Adams, political commentator, tech evangelist and creator of the popular cartoon strip Dilbert, "The biggest industry of the future, the one with the most dollar amount, will be online education. Colleges will eventually have to disappear because they don't really make sense for the price." Adams is usually spot-on with most of his predictions.

Online education has many advantages. The costs can be drastically brought down, they can service all remote areas, timings can be made much more flexible, syllabi can be updated more frequently and more customized courses can be added. The online world can accommodate a long tail. The only thing required is government approval which can even promote a new online university culture if it wants to. In fact all the major online EdTech players can be the universities of tomorrow. BYJU'S is already the globe's most valuable EdTech company.

Collaboration players are tailoring their offerings to suit the online class. For example Microsoft Teams came out with an amphitheatre mode to make students more comfortable. But a real game changer could be Virtual Reality to beat staring at a screen all day. In geography class you could visit places around the world virtually, visit them in the past in the history lesson. Medical students could get familiar with the human body along with applications in subjects like engineering, architecture, archaeology etc.

**The fall of Hollywood/Bollywood:** It was Annus Horribilis for studios, production houses, cinema halls... in fact the whole ecosystem. It will take years for them to get back to some amount of normalcy and they may never return to full form. The biggest beneficiary has been the OTT industry which was a big bandwidth guzzler and saw a record number of new users. This will continue with the rise of SWFH culture. Also raising traction are things like virtual concerts and virtual events.



WhatsApp, Instagram, Uber, Ola, Paytm, Xiaomi, Vivo, Venmo, Slack, Square, Pinterest, WeWork, Snapdeal, GoFundMe etc. (Even Zoom came closely in 2011). Most of them dominated the 2010s. The startups that will dominate the 2020s have already been conceived/funded/launched and they would have been heavily influenced by the Covid crisis. They will cover both established and the above-mentioned emerging areas.

#### **Record profits for**

**The No Touch Era:** This year municipalities in India used drones to sanitize streets while the police used them to monitor curfews. Drones can be used for anything from delivery to surveillance to surveying. Here too legislation was holding them back but they have huge potential. Waymo (parent company Google) got permission to launch a driverless car service in America.

IoT devices already outnumber human beings on this planet and have a great potential to form a global network of data collection and transfer unprecedented in history. Robotic assistants will be handy as receptionists and entry points at airports, train/bus stations and large buildings. VR robots can be used for a host of things.

All this will power Industry 4.0 which will be indispensable for business continuity in a world where natural disasters and pandemics strike. Dark or lights out factories will be of great value. Suddenly Smart Cities with smart utilities seem closer especially if we can get our 5G act together.

The cloud world has become all the more indispensable as data is increasing quickly in geometric proportions. We already have millions of data centres which are accessed by billions of devices. The governments are getting into the act. Data analytics is getting more sophisticated by the day and it will be all held together by AI, Machine Learning and Deep Learning.

**Next-gen startups:** After the financial crisis of 2007-08, the following were launched in 2009-10:

**tech:** It has been a great year for tech and many companies have made record profits. Now most of the traditional companies will be forced into digital transformation and the dependence on tech will grow ever more so. In July this year, Tesla overtook Toyota as the most valuable car company in the world. Since then its market capitalization rose to half a trillion dollars.

Apple touched a marcap of 2 trillion in comparison and has since diversified its manufacturing to countries like India and Vietnam. Giants like Microsoft and Amazon benefited greatly from the increasing use of cloud and the latter by ecommerce too. The trillion dollar club (marcap) is filled with companies from the tech field. A time came this year when Facebook, Apple, Amazon, Google and Microsoft had a combined weightage of approximately 23.5% in the S&P 500 index. Chinese and Korean players also saw the profits continue.

In India companies like HCL had great quarters while TCS became the most valuable IT services company in the world. The biggest success story was Reliance which is positioning itself to be a top tech company. It has invested in many tech companies and has received funding from more than a dozen players involved with technology.

In both the good times and bad; In normal times and crisis; Whether there's a pandemic or not; If there's only one thing you can depend on then its technology. That will continue to be a high growth area well into the 2020s.

Re-imagining Banking With Mixed Reality  
Video Games Can Improve Brain Function

VOL. 33 | ISSUE 2 | FEBRUARY 2020

**PCQUEST**  
4.0 Is The Convergence Of All Tech Superpowers

—Chris Wolf  
VP & CTO, Global Field & Industry, VMware

**FUTURE OF TRANSPORTATION**  
Urban travel will be a big challenge in the upcoming decades

Special Subscription offer on page 60  
76 pages including cover

Alexa—Let There Be Light!  
Uber, Casper, WeWork, Peloton — Unicorns, Out Of The Stable?

VOL. 33 | ISSUE 3 | MARCH 2020

**PCQUEST**  
How To Become A Data Scientist

—Sonya Hogg  
Co-founder & Chief Operating Officer, Instructia Learning

**COLLABORATION IN THE TIME OF CORONA**

Special Section on **WOMEN'S DAY**

Special Subscription offer on page 60  
76 pages including cover

5 Best Time & Productivity Tracking Tools  
Surge In Social Gaming During The Lockdown

VOL. 33 | ISSUE 6 | JUNE 2020

**PCQUEST**  
On-Demand Mobile Apps Are Mushrooming In 2020

**MOBILE WILL RULE THE POST-COVID ERA**  
The smartphone will unleash digital transformation

Special Subscription offer on page 58  
76 pages including cover

Catch Tech Leaders On Our YouTube Channels  
Digital Payments Evolve From "Nice To Have" To "Essential" Service

VOL. 33 | ISSUE 8 | AUGUST 2020

**PCQUEST**  
Will Covid-19 Accelerate Adoption Of Automation In India?

**CLOUD, COLLABORATION & PRODUCTIVITY**  
Videoconferencing, VPNs, Desktop-as-a-Service... it's all happening!

Special Subscription offer on page 52  
76 pages including cover

Almost every industry in 2020 went in for a sea change as a technological upgrade became imperative for business continuity

# Focused Digital Campaigns...



**"IN THE MIDDLE  
OF DIFFICULTY LIES  
OPPORTUNITY"**

Enable your business in  
this challenging time  
with  **CyberMedia**  
digital offering...



**We ENGAGE with  
your AUDIENCE**

Large Enterprise / Medium Enterprise /  
Small And Medium / Channel Eco-System /  
Start-up / Developer / End Cosumers /  
Gaming Community

## HOW TO BETTER A DIGITAL BRAND STRATEGY



Branding



Response  
Generation



Webinar



Virtual Round  
Table



Custom  
Program



Virtual  
Event

Create a successful brand focused campaigns with :

**Harminder Singh**, Associate Vice President - Online Expert, [harminders@cybermedia.co.in](mailto:harminders@cybermedia.co.in)

# THE A TO Z OF 2020

A year of momentous upheaval where the Covid crisis took everyone by storm, the lockdown led to great technology innovations and Big Tech continued to flourish amid the recession

Sunil Rajguru  
sunilr@cybermedia.co.in



**A** **for App Bans:** The Covid crisis led to a certain amount of disillusionment with China and the border dispute with India followed. The Indian government started

with a succession of Chinese app bans. The US government, having security and trade issues of their own, followed suit. While the app battle between the US and China was that of equals, it remains to be seen



if all this gives a filip to the Indian app industry.

**B for Bitcoin's low & high:** When Bitcoin was introduced in 2008, many established players called it a fraud, but it was embraced by a handful of enthusiasts and geeks and it survives well into the 2020s. While the 2010s do its many highs and lows, 2020 was also a roller coaster. In March it fell below \$5000 but towards the end of the year it was in the region of 20K.

**C for Contact Tracing:** The good and the bad of tech together. It's pretty great that during Covid, governments can monitor live its citizens and keep track of all its citizens and in the process manage the global epidemic that has brought countries to a halt. A fine example of e-governance implemented quickly. But what about monitoring citizens and knowing where all of them are when there is no epidemic?

**D for Driverless everything:** California gave permission to Google-owned Waymo to conduct driverless car rides, called robotaxis, and thousands have already used it in the trial runs. Drones were used to spray disinfectants in the streets in many Indian cities and were also used to monitor social distancing during lockdowns. The technology for drones-driverless cars was present for many years, but now the Covid No Touch Era gave governments the incentives to go ahead with legislation to allow it.

**E for Educational transformation:** Students of

all ages and geographies across schools and colleges got a taste of online education. Some of it was good. Some of it was bad. Some of it is temporary and some of it will become permanent. This will give a boost to low cost education and those who live in remote areas. The ease of introducing new courses and updating syllabi is a boon. The US education industry is already groaning under a \$1.5 trillion student debt (not even the GDP of most countries).

**F for Foxconn:** Foxconn is shifting manufacturing of certain units of iPhone 11 to India. This is a big boost to Make in India and this year we emerged as the No. 2 mobile manufacturing country in the world. Foxconn is planning to shift out certain Macbook and iPad operations to Vietnam. The world is getting ready to reduce its dependence on Supply Chain China and it will be no different in tech.

**G for Generations of Telephony:** Did you know that millions of people still use 2G in India. The rest of the users are distributed between 3G and 4G. While technological acceleration covered most fields, not so much 5G in India. Reliance Chairman Mukesh Ambani announced at the last Annual General Meeting that they can implement 5G within a year of getting the contract. But with the way it's going, India may give 5G a miss in 2021 too.

**H for Hacks all kinds:** Hackers wait for special occasions, celebrity milestones and crises to strike and this time it was no different. Everyone right from the World Health Organization was attacked and ransomware cases increased. The most high-profile was the Twitter hack where 130 top global verified accounts were taken over. Later the Twitter account of the website of Prime Minister Narendra Modi was also hacked.

**I for IPO of Ant Group:** Global investors put in bids worth a whopping for \$3 trillion for Alibaba's Fintech Ant Group. What was proving to be the largest IPO in history and a great global debut was pulled at the last minute by Chinese regulator leaving Chinese billionaire Jack Ma high and dry. Had everything gone as scheduled, Ant would have debuted as a \$300 billion plus company.

**J for Jio:** Jio's dream run continued in 2020. It consolidated its market share, positioned itself as a future 5G player, but more importantly got a host of investments crossing one lakh crore Rupees: Facebook, Google, Qualcomm, Silver Lake, Vista Equity Partners, General Atlantic, KKR, Mubadala, PIF, Abu Dhabi Investment Authority etc. Jio established itself as a global tech player.

**K for Ka and Ku bands:** Elon Musk's SpaceX is

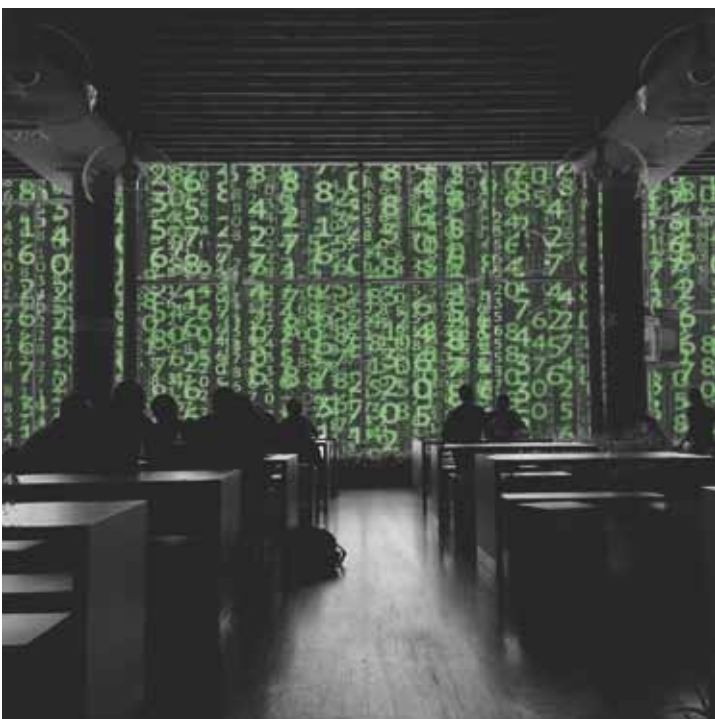



launching revolutionary Starlink satellite internet service for the world. The beta trials started this year as the number of total satellites up there was in the region of one thousand this year. Once this project is completed, then no place in the world will be Internetless. It will use both the Ka and Ku bands.

**L for Ledger:** While Bitcoin gets too much mind share in the global public, cryptocurrency not so much. But even less is the concept of Distributed Ledger on which all this is based, Blockchain. This is quite handy for the banking industry and indeed many have finally warmed up to it. It was also discussed extensively to boost up the supply chain, something that came into sharp focus during the Covid crisis.

**M for mRNA:** While many viruses have been around for thousands of years and some vaccines took hundreds of years to develop. That way Covid

ushered in the tech era for vaccines. The messenger RNA vaccine was created on the computer and replicated easily on the machine. In 2020 itself the vaccine went from drawing board to being distribution ready. If it succeeds it will revolutionize medicine.

**N for Net Neutrality:** When US President Barack Obama took over in 2009 he introduced his own set of Internet rules. When his predecessor Donald Trump took over, he scrapped the Obama era rules and returned to status quo. Now that Trump is on his way out, Silicon Valley is looking to what new rules will come with the new regime in 2021. Ajit Pai, Chairman of the Federal Communications Commission, also resigned with regard to this.

**O for OTT:** With movie halls shut down for most of the year, people turned to OTT in large numbers and choked the bandwidths. While Netflix and Amazon Prime continued to charm, Disney+ came to India in association with Hotstar. India also has many regional players. The film industry will probably never return to its glory days.

**P for PUBG:** This became a sensation among the youth of India, so much so that many elders demanded its ban due to its “violence” and “bad



influence". However the ban finally came after the China border dispute. PUBG is of Korean origin but released by the Chinese Tencent, so the former is desperately trying to make a return under a new tie-up.

**Q for Quantum computing:** If last year Google claimed to have achieved Quantum supremacy, this year it was the turn of China. They claim to have built a photonic quantum computer that could perform certain computations 100 trillion times faster than the best supercomputer, which is 10 billion times faster than the Google prototype of 2019. The Chinese government is sponsoring a \$10 billion National Laboratory for Quantum Information Sciences.

**R for Retail:** This saw sea change this year. While traditional retail survived and boosted its ecommerce footprint, traditional ecommerce players flourished. In the US it doubled and India gained a lot of new users too. The delivery boy network expanded and did a great service to the nation during the Covid lockdown.

**S for Services:** While there wasn't much focus on this, Indian IT services also chugged along and TCS became the largest IT services company in the world going past Accenture. They have been the backbone of Indian IT, but the focus is slowly shifting to things like startups.

**T for TikTok:** The teen sensation across the world was heading to the one billion users club and in all likelihood would have gone past WhatsApp and Instagram and been No. 2 (after Facebook). It was popular in both America and India. It was a hit in both urban and rural India. Then both countries went after TikTok and now it is in decline.

**U for US Congress:** The US Congress summoned Facebook's Mark Zuckerberg, Amazon's Jeff Bezos, Apple's Tim Cook and Google's Sundar Pichai over antitrust issues. While nothing came of it (yet), the Big Tech and Big Govt fight continues. The new European Union rules in 2021 will really bring

things to a head.

**V for Virtual Reality:** This is one of the emerging technologies that showed its worth in the No Touch Era. It has applications in the medical field, education, entertainment, tourism, gaming etc.

**W for WFH:** 2020 is the year the Work From Home era really began. Before this it was an exception in most cases but now it became the rule. Almost the whole world did WFH and many had this status sanctioned for good. The proof of the pudding is in the eating and now the mindset has changed. More importantly the bandwidth has gone up and now we have enough collaboration tools to deliver the goods.

**X for Xiaomi:** Despite the call for boycott of Chinese products, Xiaomi continued to do well in India in the form of mobiles, wearables and smart TVs. Globally in mobile shipments it went past Apple to claim the No. 3 spot.

**Y for Yelp:** Came under great controversy this year when it said it would flag businesses that were considered racist. But it showed how Silicon Valley and tech companies continue to grapple with things like diversity and inclusion.

**Z for Zoom:** Zoom symbolized the Zeitgeist of the year. Video conferencing and collaboration really took off and it registered a lot of first-time users. After that WFH and online education also got a boost. Zoom had come out with an IPO and became profitable in 2019, but 2020 has proved to be their best year ever. It will be interesting to see how 2021 pans out for the collaboration industry.



# MUSK CONTINUES TO RIDE HIGH

While many industries saw a downturn, the world of tech went ahead full steam. Most tech leaders continued to innovate and grow their companies

Sunil Rajguru  
sunilr@cybermedia.co.in



**Elon Musk:** This maverick billionaire seems to be having one good year after another and has his hands in many pies. In 2020 Smart Car manufacturer Tesla became the most valuable automobile company in the world after overtaking Toyota. Then it went ahead and breached the half-trillion dollar mark in terms of market capitalization. It made it to four quarters of profits in a row for the first time ever. With that it became ready to enter the prestigious S&P 500. In a survey it registered the highest "Overall customer satisfaction of any car manufacturer".

Musk's SpaceX made a landmark when it sent astronauts to the ISS (International Space Station), thereby becoming the first ever private space company

to do so. The Starlink satellites launched also neared the 1000 mark in 2020 as they began beta testing for users for this low-Earth orbit satellite Internet service. Starlink is revolutionary and when completed, there will be more of its satellites than all other satellites put together, launched by every government in the world. The Boring Company finished the tunnel for the Hyperloop under the Las Vegas Convention Centre. Musk announced that SolarCity was now giving the cheapest solar power in the US.

**Mukesh Ambani:** If you look at the largest companies in the world, then it's the trifecta of energy, retail and tech. While they are already an energy giant, Ambani's Reliance increased their



It is for this reason that Reliance became the first Indian company with a market capitalization of \$150 billion. Reliance debuted directly at the No. 2 position in the PwC global Future Brand index in the recent 2020 list ahead of the likes of Samsung and Microsoft (Apple was No. 1). The Reliance Chairman announced at the last AGM that Jio was in a position to implement 5G within a year of getting the contract. That is big because 5G will not just power mobiles, but entire Smart Cities with all their components: Smart Homes,

Smart Cars, Smart Factories, Smart Utilities etc. So the future also belongs to 5G players and Mukesh ensured that 2020 cemented that.

So the future also belongs to 5G players and Mukesh ensured that 2020 cemented that.

**Jeff Bezos:** Thanks to Covid-19, ecommerce saw huge growth in the US and worldwide and early in

footprint this year after looking to buy out Future Group's Big Bazaar, Brand Factory and Foodhall. Amazon opposed this and took the Future Group to court, but you can bet on Reliance in the long-term. The biggest takeaway of 2020 was that with Jio, Reliance is now looking to be a major global tech player.

A look at some of the dozen plus investors that got a bite of the Reliance-Jio pie... Google, which dominates search and video (via YouTube), the mobile OS space (Android) etc; Facebook, the No. 1 tech company in the world in terms of users (add WhatsApp and Instagram to the mix); Silver Lake that has invested in companies like Airbnb, Twitter, Dell, Skype etc; KKR that has invested in ByteDance (TikTok)



& Epic Games along with Mubadala Investment Company, that owns GlobalFoundries, the world's second largest semiconductor foundry company.

When you look at the list of companies that Reliance has invested in or taken over, that list is equally diverse: Netmeds (online pharmacy), Triller (social video), Eros International-Balaji Telefilms (OTT space), Embibe (EdTech), Radisys (telecom), NowFloats (SaaS), Asteria Aerospace (drones), Saavn (music streaming), Fynd (ecommerce), Grab (a logistics startup), Haptik (AI), Reverie (regional language tech), Tesseract (AR/VR) and cable players Datacom, Hathway and Den.

the year and Bezos' Amazon crossed a marcap of \$1 trillion. Amazon got into the online pharmacy market, launched the Luxury Store mobile app and relaunched Prime Gaming, a video service. Amazon has its own logistics network with their own planes and transport vehicles and they are also getting into the driverless market big time. Another growth area of 2020 was the cloud and that's where Amazon Web Services is going strong.

While Amazon Alexa is doing well, they also came out with many Amazon Ring (which started as a video doorbell that could alert the police) products including an indoor one with a home drone and one

for the car. In the Cloud-Data world of tomorrow, Bezos is posed to dominate much more than say companies like Apple. Like Musk, Bezos has space ambitions. His Blue Origin was part of the Artemis team that got the half-a-billion dollar plus contract that will come out with an “integrated human landing system” for the next round of Moon landings. Related to that, they had a successful New Shepard 3 rocket launch.

**Eric Yuan:** Video collaboration had been around in the 2000s, but it was only Yuan’s Zoom, launched in 2011, that took it to the next level. But even he had to wait till the Covid crisis to truly showcase his great new product. This was the first real tech success story of 2020. Interestingly Zoom had become profitable and come out with an IPO in 2019 itself. At that time it was at \$36 a share which became \$70 in January and subsequently crossed \$500 later in the year.

Zoom became a verb and everyone wanted to be



on the platform. A lot of first time and home users learnt all about video collaboration only through Zoom. Depending on which geography and time period you took, it even recorded growth in the thousands of percentages. It did the job admirably in the first few months, soon other collaboration players caught up, bandwidth providers had to up their game and that led to the WFH revolution that helped companies continue working throughout the lockdown.

**Chinese Misses:** Zhang Yiming formed ByteDance in 2012, but it is more known for its TikTok, which saw a phenomenal rise in the last few years. It was poised to become the first ever non-American brand

to garner one billion active users when it was targeted by both the Indian and American governments. While Facebook got 2.5 billion users, its products WhatsApp and Instagram are in the 1-billion-club. Now the fate of rising superstar TikTok is uncertain.

Ren Zhengfei founded Huawei way back in 1987 and it really took off in the 2010s. It was poised to be the backbone of the global 5G network and that would have taken it to the next level. However security issues and US President Donald Trump’s Clean Network initiatives forced

America and its allies to dump Huawei one by one. You can imagine the potential of Huawei that despite all of this, it still came in at No. 2 in global mobile shipments in the last quarter and is going full steam ahead with China’s 5G.

Jack Ma’s Alibaba is into ecommerce, cloud and AI, all industries of the future. When he came out with the IPO of their FinTech Ant Group, it got a whopping \$3 trillion worth of bids from individual investors. But he fell foul of the Chinese government and had to be withdrawn. Meanwhile Xiaomi displaced Apple for the No. 3 spot in terms of global shipments and Tech China must be itching to take on Tech America and regain the trust of the world.

# THE INDUSTRY IS POISED FOR THE PERFORMERS & ACHIEVERS, ARE YOU???

Dataquest unveils the most credible, comprehensive industry ranking & analysis

**DATAQUEST**

**DQ  
TOP  
20**

- Financial Performance: The Top 20 IT companies: Hardware, software and IT distribution
- Thought Leadership - CEO Interviews
- Deep dive into key IT segments

CRM

PC & Smart Devices

Printers & Barcode Scanners

Security

ERP

Cloud Service Providers

Projectors

Data Management

IOT

Analytics & Big Data

Collaboration

Surveillance

External Storage

Datacentres Equipment

Hyperconverged Infra

Datacentre Service Providers

Servers

Domestic IT Services

IT Training

**Bible of Indian ICT Industry**

**Join the leaders to be the leader**  
Write to us: [rajivp@cybermedia.co.in](mailto:rajivp@cybermedia.co.in)  
Mobile: +91 8010757100

**For the submission of  
organisation profiles Contact:**  
[maildqindia@cybermedia.co.in](mailto:maildqindia@cybermedia.co.in)

# WELCOME TO THE POST-COVID WORLD

2020 has come to an end and there have been great global technological changes. There were great sufferings but great learnings too. There were many losses but now we have to look at the gains we can make in 2021. We get a galaxy of industry leaders to peek into the future and tell you what the New Normal will look like in the New Year

PCQ Bureau



SECTION  
01

CLOUD



## Collaborate & innovate at the vertical edge

“Turning disruption into a competitive advantage by creating new digital capabilities and transforming their business model, will top the priority list of business leaders. Companies need to transform themselves into



intelligent enterprises to meet the needs of their customers in the digital age. Cloud solutions that can help industries drive cost-effective transformation, and sustainable growth will be sought after.

There will be significant innovation happening across different sectors, and more so in manufacturing industries driven by the Industry 4.0 trends. By leveraging industry cloud platform, businesses across industries will collaborate and innovate at the vertical edge. Through cloud solutions that use intelligent technologies like AI and advanced analytics, companies will create compelling user experiences, digitalize and automate their operations.”

*Sindhu Gangadharan, SVP & MD, SAP Labs India*





## Optionality, flexibility and security

"We have seen many organizations begin to modernize their applications and shift to a 'cloud-first' strategy, only to hit a wall when they find that key applications cannot be efficiently migrated nor refactored to a cloud-friendly model. Due to this, CIOs are insisting on hybrid and multi cloud strategies to balance the desire for cloud agility and economics with the reality of sustaining operations. In fact, our recent Enterprise Cloud Index found that 86% of IT decision makers already consider hybrid their ideal operating model, and more than half (56%) plan to run an integrated hybrid environment within five years. Organizations will also continue to need to adopt a long-term view of their IT strategies and avoid being locked in with a vendor or service that might not work for them in the next quarter because market dynamics can change, as we have seen this year.



Additionally, security has gained emphasis in 2020 and is now seen as fundamental to every element of enterprise IT. Security in hybrid and multi cloud begins with a robust infrastructure foundation, and enables organizations to choose the right cloud for each application or workload based on the level of security required. Overall, hybrid and multi cloud solutions provide optionality, flexibility and security, and ultimately enable the right balance between scalability and economics across the enterprise – securing their spot as an essential tech trend for businesses in 2021."

*Balakrishnan Anantharaman, VP & MD- Sales, India and SAARC, Nutanix*

## Kubernetes & container adoption top priority

The disruption brought about by COVID-19 has seen the acceleration of cloud adoption, with 91 percent of enterprise IT environments now relying on cloud solutions. We can expect the cloud's popularity to continue to grow because of its proven



track record with businesses, who have successfully used the technology to rapidly respond to issues with targeted solutions. As adoption continues to accelerate among enterprises, hybrid, multi-cloud environments in particular will be a critical focus area. These technologies will offer the capacity needed to provide businesses with speed, control and security, as they prepare themselves to better work and operate with the cloud.

Kubernetes too will come into focus, serving as the abstraction layer to manage and control multi-cloud together through a 'single pane of glass'. Due to this, and despite the pandemic, the implementation of Kubernetes and container adoption will remain high priorities for businesses. In addition to Kubernetes, 95 percent of new microservices are predicted to be deployed in the containers by 2021. Cross-cloud Kubernetes will also become more common as a management tool for cross-cloud scenarios due to players like Google's Anthos and VMware's Tanzu Kubernetes Grid.

*Avishai Sharlin, Division President, Amdocs Technology*



## 4 Vs: Volume, Variety, Value & Veracity

"The year 2020 faced an unprecedented health crisis that caused major changes in the way organisations operate and function. It has fast-tracked the digital evolution of many businesses, urging them to either adopt or upgrade their existing IT infrastructures. We all know that the demand for data centers and cloud solutions are already on the rise. However, the extended lockdown and work-from-home culture further accelerated the need to adopt such technologies to ensure business continuity.

A Gartner report states that by the end of 2021, 80% of the enterprises will shift to cloud-centric infrastructure and applications, twice as fast as before the pandemic. To meet this increasing demand, data centers must be adaptable, and resilient. At the same time, they must also be sustainable and efficient.



We believe that the future of data centers will be based on 4 Vs- Volume, Variety, Value, and Veracity. By combining these Vs together, organisations can paint a picture of where the data needs to be processed, stored, protected, and transported. We believe that it is necessary to find the right balance between industrial edge computing, larger regional enterprise or colocation data centers, or cloud data centers. The next generation of data centers will witness integration of AI, Big Data, IoT, edge computing, and Software-Defined Data Center. This consolidation will enable organisations to access and manage tasks from a remote location. It will also help enhance their production and avoid the situation of data overload."

*Venkatraman Swaminathan, VP & Country GM, Secure Power Div., Schneider Electric India*

## AI-ML will lead to new business models

"India is already walking on the path to become the global hub for data centers. According to the Synergy Research Group, the data center market in India is expected to grow at 12% CAGR from 2019-2024. In 2021, and even beyond, we will see a surge in investments in the data center industry because of India's complementary strengths as a software services powerhouse, with a growing developer base and a huge population that is increasingly using digital services.



With enterprises and government emphasising on data localisation, we will witness a spurt in the demand of data centers and cloud facilities in the country. Energy efficiency will be the new benchmark for data centers. It will act as a key defining factor for competitiveness and growth as the world will be inclined towards sustainable business models using green technologies.

Cloud will continue to see increased adoption by enterprises as they strengthen their IT infrastructure and become agile and future-proof to stay ahead in the changing ecosystem. Increase in cloud adoption will further accelerate demand for new affordable as-a-service models for specific industries such as banking-as-a-service powered by cloud.

AI/ML will also lead to new business models and become truly mainstream. Usage of AI/ML will be

at its peak in the cloud and data center industry for various purposes including automating various manual tasks, solving skill shortage issues, and in sophisticated solutions for data security with minimal human interaction. At the same time, leveraging AI/ML will help enterprises with operational efficiency, deliver higher customer satisfaction, align with business objectives, and assure outcomes."

*Manish Israni, EVP & CIO, Yotta Infrastructure*

## SECTION 03

## ARTIFICIAL INTELLIGENCE



### Conversational AI becoming popular

"Conversational AI is becoming quite popular within the realm of consumer tech, and in 2021 we are likely to see it become a mainstay in the IT software as well. After all, we're seeing a "consumerization of IT" across the board. As we documented in our recent ManageEngine remote work behavior report, the majority (76%) of our respondents described AI-based chat support to be "excellent" or "satisfactory." From a user perspective, people expect the same type of experience from their IT infrastructure software as they do from their personal software. To be sure, part of this phenomenon involves conversational AI technologies, which are becoming increasingly popular, especially among younger workers."

*Rajesh Ganesan, VP, Manage Engine (A division of Zoho Corp.)*



### Operational efficiency & higher customer satisfaction

"AIOps for networking will become mainstream: Next year, AIOps will go from theory to practice for many organizations. With the increase of remote workers and the home becoming the new micro branch, AI will become table stakes for



delivering a great client to cloud user experience from client to cloud while controlling IT support costs for remote employees. IT teams will need to embrace AIOps to scale and automate their operations. AIOps cloud SaaS will turn the customer support paradigm upside down. Instead of users submitting tickets to IT, AI will proactively identify users with connectivity or experience issues and will either resolve (the self-driving network) or will open a ticket with suggested remediation actions for IT.

*AI assistants will become part of the IT team:* AI assistants will continue to get smarter and become an integral part of the overall IT team. Their efficacy will improve through learning and direct feedback from the IT team gaining their trust as valued team members. The ability of AI assistants to solve increasingly complex user issues will decrease strain and workloads for IT teams.

*Skill refresh will be one of the biggest barriers to AI adoption:* Evaluating and implementing AI solutions calls for investment in the IT team. Forward thinking businesses will invest in new skills required by the IT leadership so that they can better understand how to evaluate and implement AI solutions across the business.

*AI will be a game-changer in helping enterprises shift to remote work:* Leveraging AI helps with operational efficiency and helps deliver higher customer satisfaction. It also helps enterprises better align with business objectives and assure outcomes."

*Pankaj Kitchlu, Systems Engineering Director (India-SAARC), Juniper Networks*

## SECTION 04 AUTOMATION

### Opportunities for no code/low code automation

"As companies navigate the impact of COVID-19 and work to outmaneuver uncertainty, they will place a greater emphasis on automation to enhance resilience and adaptability of their business.

We will see a rise in the use of hyper-automation and automated digital capabilities with AI and ML, making software development, applications,



IT and operations more efficient and predictable. We will also witness the rise of the digital co-workers, with AI and ML augmenting human workers and helping with human + machine collaboration. This includes, for example, AI assistants helping with project management, testing or data management.

Paired with a culture of modern engineering (Agile, DevOps) and a continuous innovation mindset, automation in software development and application management are opening the door for IT to be an innovation partner to the business. Organizations will look to implement AI across the end-to-end software development lifecycle to enable faster, higher quality and more predictable deployments.

We even see opportunities for no code/low code automation in the future, or in other words, for using automation to accelerate automation itself. Finally, as businesses look to become 'cloud first' in the new normal, it is the implementation of automation and AI in the cloud that will help them get the full value of these technologies and their data. This will allow for the flexibility, scalability and sustainability needed to accelerate growth and innovation in 2021."

*Mahesh Zurale, Senior MD, Lead- Advanced Technology Centers in India, Accenture*

## SECTION 05 QUANTUM COMPUTING

### Improve accuracy & solving complex problems

"Enterprises will leverage the power of Quantum computing to solve business problems in the area of Machine Learning, Optimization and Simulation. Quantum computers help reduce the execution time for algorithms, identify complex patterns in data to improve accuracy and help solve complex problems which are difficult to solve on classical computers in finite time. Quantum Machine Learning (QML) helps address the shortcomings of both the traditional and the deep learning approach. Quantum computing speeds up the training time, as it uses quantum properties of coherence, superposition and entanglement, making the processing faster. QML manages more complex network topology for deep learning



network implementation with minimal constraint in the training time complexity. Problems suited for Quantum computing include Supply Chain Optimisation, Vehicle Routing Optimization, Financial Services Portfolio selection, Financial Services Asset allocation, Supply Chain Demand Prediction, Large Scale image analytics, Graph Theory and Network Analysis, Rare event classification such as Anomaly detection, Content Generative frameworks such as Natural Language Generators etc. For example, Covid-19 vaccines must be readily available in areas most affected by the pandemic. While setting up vaccination centres it is very important to select locations which can fulfil the demand from the affected areas. Quantum algorithms can help select the optimal locations for the centres from a given set of locations satisfying demand while minimizing cost. Quantum Optimization Algorithms can be leveraged to design the network of centres from a given location and as compared to classical methods of optimization, it uses Simulated Quantum Annealing to lower the distribution/operations cost and compute time."

*Dr. Jai Ganesh, SVP & Head, Mphasis NEXT Labs*



**SECTION 06 DEVOPS** 

**Software delivery should never stop**

*"Developers as rainmakers:*

As the world is powered by software, developers become game changers in many organizations, they are not only enablers but decision makers. The developer community and how fast it's scaled, is the driving force for change in many industries. We are already starting to see this in India where more and more attention is paid to developers and a greater understanding of just how important they are.



*Security is Quality:* Software organizations are in a constant battle between delivery speed and delivery quality. The faster they move the greater the chances they end up with a lower-quality product. Most are in a race to do things fast and also instill quality into the product. What many may not consider is that security is one aspect of quality. Organizations using lots of

third-party components in applications must pay special care to security if they want to continue to rely on 3rd-party dependencies for re-use and accelerated delivery, and handle these in an automated way throughout the pipeline. We'll see more companies implement security safeguards very early on in their development process to combat this.

*Everything Cloud:* The pandemic has forced enterprises to move much of their operations online. A big part of this is the automation of cloud infrastructure setup and updates. Right now, most of the solutions for securing the cloud setup are an "after the fact" kind of solution and alert you once your cloud infrastructure has already exhibited a misconfiguration that can be compromised. We're going to see the cybersecurity market for cloud infrastructure mature to solutions that take a more proactive approach to ensuring secure cloud config before unsecured changes reach the real cloud.

*Permanently enabling remote work:* To support remote teams worldwide, as well as enable developer productivity, IT needs to provide as much of the tools of the trade and dev/test environments as on-demand cloud services. This will reduce the management overhead to install and operate the complex DevOps toolchain itself and the environments that developers rely on, as well as ensure global coverage, scale, and self-service seamless experience. In a world where isolation and distribution of teams and processes is the reality, fully automated, quality-trusted, tools and cloud services that enable continuous delivery as well as seamless collaboration become much more critical for DevOps teams to ensure that software delivery never stops!"

*Kavita Viswanath, GM, JFrog India*



**SECTION 07 DATA** 

**Security can be a competitive advantage**

"Today, ransomware is the fastest-growing cybercrime threat. The trend of ransomware attacks has increased with the advent of the COVID-19 pandemic and has exposed significant gaps in organization's IT systems. The damage ransomware



can inflict on businesses is staggering. The key to be safe from these data breaches is to have a robust and well-tested backup.

This means ensuring that good, clean backups are made regularly and they are thorough and comprehensive. Moreover the best protection is to have an 'air gap' backup that separates the backup from the production data you are protecting. IT Leaders need to ensure backup policies and practices are regularly reviewed and tested. Cloud backup technology is the most efficient form of storage for businesses to be resilient against ransomware.

Many businesses are starting to realize that security can be a competitive advantage, and many are spending proactively in quantifying their risk posture to be able to measure and mitigate cyber risks in real-time. Whether enterprises are planning to adopt cloud infrastructure or are already cloud-native, 2021 is the year in which businesses are going to optimize cloud, both in sophistication and scale."

*Sandeep Soni, GM and VP of Engineering,  
India Operations, Clumio*

## SECTION 08 SECURITY & DATA PRIVACY

### CISOs will focus on leveraging AI-ML

"It is undeniable that 2020 has been a year of unprecedented change. As we move into 2021 and start on our path to recovery, there are some key areas that we perceive many businesses will focus and invest in.

Firstly, we will witness massive traction in applications moving from monolithic to microservices oriented application. This will be driven by businesses as they need both traditional and modern delivery architectures to satisfy their efficiency equation. Secondly, applications are the engines of the digital economy, and now more than ever, will drive the growth for various industries.

As businesses' application portfolio increases and the application landscape continues to evolve, application visibility and security are simply not optional. Businesses will need to start leveraging on AI and ML-powered technologies for application



delivery and security. And, finally, application security across the multi-cloud becomes vital more than ever with an increase in distributed denial-of-service (DDoS) and password login attacks resulting in the credentials of users being available on the dark web or businesses losing customer confidence.

CISOs in 2021 will focus on leveraging AI and ML, among other technologies, to accurately determine in real-time if an application request is from a fraudulent source, and if so, effectively mitigate."

*Dhananjay Ganjoo, MD- India & SAARC, F5*

### Numerous opportunities, but implement adequate controls

"2020 has been an interesting year and great learning experience for all of us and we expect that the effects of COVID-19 will linger on even through 2021. As the Pandemic has accelerated the wave of digitization, we have observed an increase in cloud adoption. Hence, we can expect to see a great momentum for cloud security in India and that a 'Cloud First Strategy' will soon become a buzzword here. However, we can also expect to see some initial challenges.

While the opportunities that the cloud has to offer are numerous, they cannot be leveraged securely without implementing adequate controls. Organizations are also plagued with the issue of users having excess privileges into the cloud resources and infrastructure. With the growing use of Dockers and Kubernetes, securing them has also become important. Keeping this in mind, enterprises would want to avoid the issue of swivel chair security and have a single platform that can address multiple challenges: cloud infrastructure security, identity creeps, security containers and workloads. A single platform that can give enterprises actionable cloud security intelligence and help them stay secure, prevent over-privileged identities, and be compliant in the cloud."

*Paddy Viswanathan, Founder & CEO, C3M*

### New data science-led data privacy solutions

"A red hot technology trend for 2021 we are exploring is differential privacy. In fact, Gartner has



now included differential privacy on its 2020 Emerging Technology Hype Cycle. Data privacy and mobility are huge challenges for firms when building and deploying analytics and machine learning models. The challenge is the need for protecting individuals' personal information and privacy, while still allowing businesses to derive useful business insights across their operating units and multiple-use databases. Firms face hefty sanctions if they run afoul of the EU GDPR privacy protection rules which took effect May 2018 or any other local data privacy regulation. Data science and AI-driven solutions are being created and deployed so that individual privacy and data protection compliance is maintained, and that large customer datasets and personally identifiable information can be obscured and randomized, while also not transferring ownership of that data to other business units or externally to other firms. New data science-led data privacy solutions are being implemented so that firms can query and analyze their data for holistic views of customers without breaching individuals' privacy protections. Here's where differential privacy can be of use and Synechron is exploring this as a technology."

*Hachem Ohlale, Head of Data Science & AI CoE, Synechron Netherlands*



technologies like cloud, AI, VR, etc. Integration of AI has allowed businesses across industries like retail, banking, etc. to automate various processes and add value to the system. According to a NASSCOM report, AI has the potential to add \$500 billion to the GDP if used in the right manner.

Digitalization will dominate the tech industry in 2021 and will witness a move towards a contactless future with services like digital banking solutions, automation of processes across sectors, and adoption of a hybrid working model. Work from anywhere will help bridge the gap of skills demand and supply. In 2021, talent will play a major role, and will need to be constantly re-skilled and unskilled in the technologies of the future to unlock their potential."

*Shreeranganath Kulkarni, Chief Delivery Officer, Birlasoft*



**Infrastructure should be inherently secure by design**

"The success factors for businesses in 2021 first and foremost would include a 'digital-first' mindset; secure, cloud-optimized networks and infrastructure; smart use of advanced analytics like AI, automation, open APIs and analytics; and data management. Collectively, these form the foundation for businesses to create and sustain positive employee and customer experiences.



As budgets remain under immense pressure and boardroom agendas are high on responsible cash management, we expect forward-looking businesses to explore alternative consumption models that allow them to take advantage of opex-based services, as well as enter into support and managed services engagements.

Even though automation is a potent factor in business transformation, the pandemic has renewed organizations' efforts to harness its many benefits, across both B2B and B2C worlds. Similarly, AI and ML will augment, not replace, people skills.

To provide effective, digitally focused customer experiences in 2021, organizations that have integrated their channels and connected them to the ecosystems that their customers inhabit, will constitute the winners' circle.

Security will remain a concern and focus

**SECTION 09 DIGITALIZATION**

**Digitalization to dominate tech industry**

"The potential of technology is unlocked faster with newer innovations every day, which is helping enterprises move towards their digital transformation journey and change existing business processes, cultures, and customer experiences.

The pandemic has worked as a catalyst for digitalization, which has pushed offline businesses towards the online mode and adopt



should continue to be embedded in all aspects of the organizations' technology estates - whether applications and workloads are running on-premises or in a public or private cloud, and irrespective of whether people are working from home, the corporate office or remotely - infrastructure needs to be inherently secure by design, not something that's 'bolted on' as an afterthought."

*Raghuvver HR, Senior Director- Sales, NTT India*

### Greater push towards information sharing & collaboration

"The widespread impact of COVID-19 has been felt across industry verticals with the pandemic inducing a major shift across enterprise operations. As businesses look to build on their digital capabilities to bring greater efficacy in business operations and ensure enterprise safety, here are some of the emerging technology trends that will shape the future of enterprise in 2021.



Strengthening identity framework and 'zero trust' approach: The rapid transition to remote working environments and increased usage of cloud and collaboration tools are forcing enterprises to look beyond the traditional perimeter-focused approaches to security. A renewed 'zero trust' approach to identity and access management policies and incorporation of new models for cloud access and security will take the center stage in 2021.

Blending the power of AI and ML in Business Operations: The integration of AI and ML in business operations will gather steam as more and more enterprises look to develop new innovative approaches to drive business efficacy. However, the enterprise will need to ramp up efforts to recruit, train, and educate the workforce to ensure the quality of output and to deal with transparency, ethics, trust, and compliance concerns.

Collaborative approach to tackle ever-evolving cyber threats: Given the growing complexities in cyberspace and increased frequency of attacks across industries, there will be a greater push towards information sharing and collaboration on security matters. This will include sharing of threat intelligence and best practices to shore up overall defense against

emerging threats."

*Praveen Jaiswal, Co-founder & Head- Business Development, Vehere*

### Industrial sector will look to IoT based solutions

"The ongoing pandemic has changed all industries and has had a tremendous impact across sectors. We had to reimagine the way we work and maintain business continuity. Many of those learnings from 2020 will be crucial for 2021 too.



Enterprises will see a big push towards application modernization and migration to the cloud. Accessibility through mobility and online applications will see a surge as organizations will continue to operate with a dispersed workforce. Increased dependence on cloud-based computing and application support will enhance focus on cybersecurity to prevent malware attacks and preserve data privacy and confidentiality.

Data engineering will experience an increased focus across industry sectors with a more in-depth focus on ML and Deep Learning-based data modeling for analytics and AI support for better decision making. We will also notice increased automation using AI tools and DevOps based testing and release management.

The industrial sector will look at factory automation and asset management efficiencies through the rendering of IoT based solutions. This will be coupled with augmented and mixed reality-based solutions for better customer experience, on-field support, training, and user experience applications."

*Piyush Jain, VP and Head- APAC Delivery, QuEST Global*

### Treat security policy as code

"We're looking at a future where big data is fueling innovation. And, we expect data mesh to help enterprises embrace competitive growth and innovation. Data mesh applies platform thinking to create a self-serve data infrastructure that treats data as a product.

We have also been tracking eXtended Reality tech, and are excited to see how creative technologists and business leaders leverage the tech as part of both

customer experience and infrastructure modernization.

Increasingly, we are seeing a shift from accidental hybrid or whole-of-estate cloud migration plans to intentional and sophisticated hybrid, poly or portable cloud strategies, where organizations apply multidimensional principles to establish and execute their cloud strategy.

The complexity of the technology landscape today demands treating security policy as code: define and keep policies under version control, automatically validate them, automatically deploy them and monitor their performance.

We are also witness to a push for the development of decentralized identifiers — globally unique, persistent and self-sovereign identifiers that are cryptographically verifiable — as a major enabling standard. We're excited by the premise of this movement and have started using the concept in our architecture."

*Saptarsi Hore, COO, ThoughtWorks*



intelligent remotely accessible business solutions and at the heart of it all AI will be the trends shaping 2021. Nevertheless, 2021 is a big year and there is much to look forward to besides the Corona Virus Vaccine. This will be the year that organizations will focus on recovering from the pandemic hence; the spotlight will be on digital investments that can drive transformation strategies."

*Sunil JNV, EVP, Aspire Systems*

## Scale it with AIOps

"Technology trends for 2021 will have 4 big themes interwoven with each other; namely – Cloud, Automation, Intelligence and Security. Nearly 80% of enterprise workloads are still on-premises. The enterprise march to the Cloud will accelerate in 2021 with emphasis on automation and intelligence in the entire lifecycle; from discovery, transformation, migration, to monitoring. Intelligent IT ops will be the de-facto way of automating IT operations.



2021 will see the first major wave of sensitive applications migrate to confidential computing infrastructure, both on-premises and in cloud. This technology protects code by running it in a secure enclave and always keeps the in-memory data encrypted. It also can provide provable attestations on the integrity of the code. The industry alliance, formed in 2019, to standardize it and the recent spate of offerings from major cloud providers will accelerate the adoption.

On AI front the enterprise action has moved from validation to production already and 2021 will see AI scale throughout the enterprise with the help of AIOps tools and platforms. Right from model development, testing, deployment, governance and monitoring the entire AI lifecycle will be largely automated."

*Pandurang Kamat, CTO, Research & Innovation, Persistent Systems*

## All about Internet of Behavior—IoB

"2020 has been a trendsetter, a business conundrum that had every industry leader find unique and highly innovative ways for business continuity. The pandemic has completely disrupted the way we work and our work place as we know it and it is never going to be the same again. Hence, it is inevitable that it leaves lasting industrial shifts in the coming years.



Gartner predicts that 2021 will be all about "Internet of Behavior (IoB), which is a data science that analyzes the behavior of people especially in the workspace. However, be it Gartner, Forbes or Forrester all believe that 2021 is going to be all things remote, which I personally agree with after analyzing the rapidly transforming work culture.

Digital technologies like Distributed Cloud, enhanced Cybersecurity, Hyper automation,

## Betting big on AlaaS—AI as a Service

"As-a-Service (aaS) has already become the norm to become a truly digital-native enterprise. The new trend in theaaS model is Everything-as-a-



Service (XaaS) where services rendered and delivered will completely reside on the cloud with virtual access to almost everything. Tools such as IoT and AI will play a crucial role in building those services, or augmenting existing services to achieve the digital-native status quo. Many IT industry giants are already betting huge on AlaaS (Artificial Intelligence as a Service) with new line of services such as digital assistance, cognitive computing, machine learning, business intelligence, and so on."



*Neelesh Kripalani, Sr. VP & Head- CoE,  
Clover Infotech*



### IoT at forefront of all transformational programs

"Social distancing, self-isolation and work from home are part of our 'New Normal'. Staying connected is a human need, and, unintentionally, this pandemic has brought to light the true value of technology for businesses, individuals, and, even the governments. I firmly believe that 2021 will see IoT at the forefront of all the transformational programs in large to medium to even small enterprises. IoT will be at the core of driving data-driven customer experiences in key industry verticals including Retail, Healthcare, BFSI, Manufacturing, Agriculture and even the Social sector! The post Covid19 world will see a surge in spend on buying personal vehicles, spike in connected healthcare solutions to manage illness and monitor health with wearable technology becoming more affordable, and a major consolidation in real estate with rise in demand for smart offices."



*Dr Rishi Mohan Bhatnagar, President,  
Aeris Communications*



### Robotic surgeries to see a rise

"In addition to the continued progress of AI, IoT, Data science, Cloud across various sectors, in 2021, we will see an increased focus on Ecommerce,

Collaboration tech, Digital Healthcare and Cyber Security.

E-commerce will witness accelerated innovation for on-the-go shopping through mobile and social selling, omnichannel experience, virtually assisted shopping, and on on-demand fulfilment and delivery including supply chain optimization, warehouse robotics, carrier route optimization, and drones for faster delivery.

Collaboration tools including voice and video collaboration, virtual white boards, remote team and project management solutions, immersive technologies (AR/VR) for office environments will see a sharp upsurge.

In Digital healthcare, AI and data-based expedited drug discovery, tele-consultation, connected healthcare, predictive diagnosis through wearables, and even robotic surgeries will see a rise.

Security will become key and distributed and secured ledger systems such as blockchain for digital transactions and digital assets will pick up."

*Pankaj Sachdeva, VP, Innovation & India Site Leader,  
Pitney Bowes*



### Increasing SaaS start-ups

"This year we have witnessed an accelerated adoption of AI and Cloud-native technologies to meet business goals and revolutionize experiences for customers. AI is more than just a buzzword, it has become a core part of the business and accelerated innovation in the virtual environment. We have significant ground to cover through the use of AI-guided tools based on deep learning models and algorithms, that enable real time data gathering, driving intelligent services, creating smart products and valuable insights. The coming year will witness AI taking the forefront as companies will navigate through AI-led platforms to build solutions that spearhead the next curve for enterprise innovation.



The other trend to watch out for are cloud-native advancements, born from open source and incubated in public clouds, which will drive quick development. This successful migration will allow organisations to scale and improve our customer and developer experience. India will see an increasing number of SaaS start-ups purely because of the potential of that technology, and supporting factors such as skilled talent and smarter customisation for a diverse customer base”

*Saurabh Saxena, VP-Product Development, Small Business & Self Employed Group, Intuit*



## Connected TV & Buy Online Pick up In Store

“The world of retail is undergoing an unprecedented wave of innovation. We believe that 2021 will be the year which will witness emerging trends such as Connected TV to become a marketing mainstay along with development and adoption of a future-proofed solution for online identity that does not rely on third-party cookies.



Adding the biggest value in the coming years, brands and retailers need to deploy an omnichannel strategy in the emerging concept of BOPIS (buy online pick up instore) would act as a critical milestone to enhance customer experience journey.

We also observe pivotal changes and adoption of newer technologies like programmatic and AI that are paving the path for more efficient and smarter technology led future. Increased accessibility of cloud-based and AI technologies will enable many businesses to move their ad tech operations from agencies to in-house and benefit from cost savings and quicker turnaround time. The growing focus on data security and compliance will further drive this trend.”

*Taranjeet Singh, MD- South East Asia & India, Criteo*



## Tech to empower with real time insights

“In the pre-pandemic era, Technology was in the hands of the employees especially in MSME business. The COVID-19 pandemic has forced digital transformation on business in every industry. 2021 is an inflection point where businesses of all sizes, especially

the MSMEs, should provide access to their technologies and tools to their customers, suppliers and service providers. Technology that not only promotes self-service to every stakeholder in business but also empowers every stakeholder in business with real time insights. Integration and interoperability are key ingredients for success.



Businesses will adopt SaaS platforms that are secure, open, agile, intelligent, cognitive, elastic and scalable.

Technologies that help consumers enjoy self-service experiences like express-checkout counters, kiosks, RFID, endless aisle and technologies that help in offering personalized experiences such as computer vision, AI/ML will get mainstream during 2021. The push for the adoption will come from the consumers who are exposed to the best of experiences and they will start demanding the same from their local businesses.

In summary, 2021 will result in significant improvement in customer experience driven by self-service and personalization through open platforms.”

*Kumar Vembu, CEO & Founder, GOFRUGAL*



## Online shopping has changed forever

“The pandemic has led monolithic technology to become obsolete faster than we could have ever imagined. Like other sectors, commerce has been no different and has been witnessing a 360 degree turn with respect to consumer behaviour. The UN Trade and development body, UNCTAD, recently announced that the COVID-19



pandemic has changed online shopping forever with the greatest shift to online shopping happening among consumers in emerging economies. As per the Economist, mobile apps are predicted to become the second most important channel for engaging with brands, after social media.

With the boom in digital commerce, it is imperative for online businesses to quickly adapt to these seismic shifts, to expand their business and to achieve client loyalty and stickiness. Many online

vendors are partnering with trusted technology service providers to leverage the benefits of innovation and speed-to-market that providers bring to the table. As customers demand more personalised engagements, 2021 will continue to herald in an increased focus on customer and user experience, which will no longer be a differentiator but table stakes for online businesses.”

*Vivian Gomes, SVP & Head- Marketing, CSS Corp*



### **Clunky CLM software will be a punishable offense**

“More Cloud Spending means more cloud-based contracts: Increased spending on cloud-based technologies through 2021 is expected to lay the ground for further value addition and technical advancements in Customer Lifecycle Management (CLM) software as companies are expected to dedicate a large portion of their IT spends to cloud-based technologies.



AI-powered contracts become the new normal: By late 2021, AI will cease to be a buzzword within the CLM industry. CLM providers will be expected to integrate AI as a standard feature as businesses will continue to adopt automated, AI-powered IT practices.

Enhancements will make CLM software effortless: In 2021, slow and clunky CLM software will become a punishable offense. Software with an intuitive UI and UX backed by Natural Language Processing will see maximum uptake. Expect CLM to evolve and look a lot like seamless, consumer software.

Security to rule the roost: Vendors whose SaaS offerings are built on secure cyber architectures and provide options in terms of implementing cyber security measures are expected to witness strong customer demand through 2021. The proliferation of remote work means providing enhanced security, privacy, compliance and transparency will become top priority.”

*Harshad Oak, General Manager- Customer Adoption & Value (APAC & MEA), Icertis*



### **More deployment of automated fleet telematics**

“2020 is likely to have a long-lasting effect on businesses. Amongst all the technology enablers it has brought to the forefront, the most critical is- the

rise of location-intelligent solutions that are likely to drive support for the ‘new normal’, almost across every sector. One industry that is most likely to be impacted is the fleet management industry.



With e-commerce sales skyrocketing, thanks to social distancing, brands will be thinking ahead to 2021 and how to best manage their fleets. This is where geo-aware planning and location enabled fleets will come in.

Bringing in operational efficiencies: Real-time fleet trackers will empower managers to visualize delays and potentially costly scenarios, monitor safety and road conditions while improving driver experience, enroute to a depot, warehouse, or final destination.

Meeting short-term and long-term environmental goals: Electric vehicles will pick up steam in a bid to build back a better world. Brands will opt for electric fleets, beyond environmental concerns, considering longer durability and lower overall associated costs.

Enhancing overall customer experience: More firms will deploy automated fleet telematics to plan accurate ETAs, real-time status updates on inventory and provide automatic updates to customers. This will in turn enhance company-customer experience, thus helping build customer trust and loyalty.”

*Ankush Chatterjee, Head- Product Portfolio Management, APAC, HERE Technologies*



### **Expect a hybrid model**

“With the pandemic, 2020 saw an accelerated pace of digital transformation across the world and in India. The number of malicious attacks and cyber frauds has also risen considerably across the globe, with newer attack vectors being discovered and known vectors being used in new ways to disrupt businesses and compromise security.



With employees working from remote locations, businesses will now have an opportunity to look at evaluating the robustness of their IT security. IT and security leaders have taken forward-looking

approaches to keep pace with and adapt to evolving IT needs and I've been seeing an even stronger push towards hybrid strategies more in recent times, even in traditional industries where IT workflows made do with just on-premise solutions.

Another change that we have seen is in the way sporting events and entertainment has been consumed over broadband/OTT platforms. This will continue in 2021 as a hybrid model as people venture out of their homes and consumers will continue to have higher expectations from platforms to deliver exceptional digital experiences. I do believe 2021 will be an experimental year for both technology providers and consumers in a positive direction. There's no doubt that cybersecurity will take more priority in technology trends that shape how digital experiences are built and consumed."

*Prasad Mandava, MD India & VP-Engineering,  
Akamai Technologies*

## 5-year adoptions being done in 5 months

"The year 2020 has been a year of learning and innovation for most enterprises. As we enter 2021, we will see communications and high-tech enterprises brace themselves to take advantage of the next wave of outsourcing opportunities to upgrade their process performance, productivity, revenues, and cost savings. And, equally important, they will prepare themselves to fuel the revolution. The scope of outsourcing has expanded dramatically in recent years. So, too, have the benefits of outsourcing from simple IT cost reductions to dramatic improvements in efficiency and productivity through innovations! Technologies and adoption of it has accelerated and things that would take 5 years for adoption are now looking like being adopted in 5 months!

As the evolution continues, several trends are emerging and building upon one another in a way that will fundamentally alter the role of outsourcing's contribution to improving overall business performance. Some of the trends that we see emerging are an increased focus on strategic partnerships, automation, use of intelligent service desk, increase in cloud services as the use of



collaboration tools increase, and focus on mobile-first development."

*Akash Bhat, CEO, Allied Worldwide*

## Automate Everything the way forward

"The three key tech trends to watch for 2021 are going to be technologies that will have a heavy focus on Business Resiliency, Cyber Security, and Automate Everything. Business Resiliency related technologies will be those that facilitate work from anywhere with adaptable infrastructure, workstream collaboration, and SaaS based business services.



The world has learned its lesson from the impact of Covid-19 hence technologies that will safeguard business continuity planning through integration with key business services will be a key focus for CIOs.

With the rapid onset of digital embrace, Cyber Security related technologies will be playing a paramount role in guaranteeing secure business operations. Advanced threat protection, endpoint detection, and response and content control will lead the way in 2021. Cyber protection strategies will get incorporated into business strategies. Automate Everything will be driven with increased rigor to enable organizations to achieve digital operational excellence. Chatbots, RPAs, API driven platforms, and AI models using advanced ML techniques for high impact high volume transactions will become mainstream in 2021."

*Heminder Ahluwalia, COO,  
Ascent Business Technology Inc*

## IoT key in next-generation data analytics

"Digital transformation is no more a trend but a necessity to be ahead of the competition by improving efficiency, reducing costs and enhancing customer delight. Encompassing a wide range of technologies including Cloud, Big Data, AI/ ML and blockchain, it enables businesses to automate processes and focus on innovation. The digital solutions market today is



valued around USD 469.8 billion and is growing at a CAGR of 16.5% to reach USD 1009.8 billion by 2025. We see Internet of Things (IoT) devices penetrating the market at a faster rate and this is going to be at the front and center of next-generation data analytics.

Digital solutions, data engineering, cloud infrastructure, low code application development, smart test automation and AI-based text analytics are revolutionizing the way businesses work and will continue to be areas to watch out for in 2021. We also see mid-market solution providers pivoting around technology solutions such as Mendix, Striim, Mulesoft, Denodo etc. through partnerships to speed up market adoption of these technologies across different verticals."

*Ram Sukumar, CEO & Co-founder, Indium Software*

### **SMEs to increase their presence online**

"Recent events have resulted in operational and strategic shifts in small and medium businesses. This, along with the availability of innovative digital solutions, is driving usage of technology deeper into the customer segments.

Remote working is here to stay and technology will enable hybrid working environments, where employees can access their data from anywhere. Businesses will use multiple types of devices to access their business data. They will benefit by exchanging relevant data seamlessly with other businesses and institutions. On-premise/on-device software will be used for its convenience and privacy. Businesses will combine this with the data exchange/distribution capabilities of cloud computing, to remain 'always connected'. Data security and privacy will be of paramount importance.

SMEs will increase their presence online. Ability to list products and services online, accept digital payments, seamless integration of inventory across marketplaces is the need of the hour. Businesses will need automation to manage leads, contacts, customer interactions, single customer view, and other ways to remain closely connected to the customers. Easy to use CRM products developed keeping small businesses in mind will serve this purpose.

SMEs will benefit by re-thinking about the ways



they operate, with increased digital adoption and implementation of innovative technology."

*Nabendu Das, Head-Engineering, Tally Solutions*

### **Increase in DAPs for employee-facing applications**

"2021 will be all about shifting gears from immediate response strategies to systemic business changes for long-term sustainable growth. As organizations continue their digital transformation journeys at an accelerated pace, they are realizing the need to improve technology adoption in addition to deploying new technology.

They are increasingly turning to digital adoption platforms (DAP) to support remote training, L&D initiatives, onboarding and change management.

Organizations have increased the number of digital applications within the organization, due to which there has been an increase in DAPs for employee-facing applications. Remote working is here to stay and in such a scenario, organizations' interest in DAPs, especially for enterprise applications, will continue to rise.

Digital adoption as a category is growing exponentially, year over year. According to the DAP Playbook by Everest Group, the global DAP independent technology vendor market size will grow by 65-75% from 2019 to 2022. While the adoption of DAPs is still at a nascent stage in India, as organizations look to strengthen business resiliency, DAPs will play a vital role helping enterprises solve their technology adoption challenges."

*Khadim Batti, CEO & Co-founder, Whatfix*



### **Gig economy to accelerate**

"The recruitment space is undergoing tech intervention and innovation in two main areas: Screening and matching and gig working.

In 2021, we expect companies and recruiters to increase their dependencies on AI, ML and deep learning technologies to accurately screen candidates at scale and effectively match them with the most

relevant and promising opportunities. The problem to solve for is candidate to company fitment, which ML algorithms will continue to predict with better accuracy as we continue to train data models with wider sets of data points.

The second trend, gig working (and the gig economy), we expect to accelerate in terms of adoption from companies and candidates alike, and tech has a role to play in terms of serving all parties with tailored opportunities and talent."

*Vikram Ahuja, Co-founder, Talent500*



**Expect a hybrid working model**

"HR tech has rendered great support to organizations to ensure business continuity in the year 2020. Despite the hardships that the companies have undergone, they are now fully-equipped and prepared to run businesses undisrupted in any kind of work environment. Companies learned to leverage the power of HR technology to manage and improve employee performance remotely.

Many organizations reckon that HR trends that had been predicted at the beginning of 2020 have gone into smoke, which is not true. The pandemic, though forced us to make many irreversible decisions, has accelerated the change in the HR industry. It seems we embraced a decade worth of technology adoption in less than one year. Remote working and workforce spread across the globe are no more distant realities. In 2021, the new normal will blend in with our familiar normal to bring out a hybrid working model and more resilience in the HR industry.

Remote collaboration enables and empowers us to maintain the company work culture among the distributed workforce. Organizations will come up with many high-end collaboration tools and techniques to create a diversified workforce that lives out the core values of the company every day."

*Shankar Krishnamoorthy, Co-founder & CEO, Synergita*



SECTION 11 FINTECH



**Next wave of transformation: Process automation**

"Over the years, technology has deeply influenced the growth of the banking industry. The onset of COVID-19 has only accelerated this evolution. With businesses and customers continuing to rely on remote operations, technological advancements and implementation in this sector would continue to gain significance in the foreseeable future.

While the early response to the pandemic focused on digital customer experiences, the next wave of transformation would focus on process automation by organizations. Emerging technologies such as AI, RPA, NLP, and blockchain coupled with innovative business models will redefine the way organisations operate in the coming months.

Apart from these, technological developments such as open banking, neo banking is set to disrupt the banking and finance space. While financial institutions are streamlining their process through tech innovation, GICs (Global in house centers) have proved to be effective in supporting parent companies in their digital transformation journey. There's no doubt that GICs' have metamorphosed over the years. With growing digitisation and tech advancements, it would be interesting to see how these captives will help organisations drive their strategic functions"

*Santhosh Mahalingam, MD, Mashreq Global Services*



**FinTech to improve financial health**

"2021 is going to be different for the BFSI sector in terms of the business model. Until now, every banker has only looked at the past data and made a credit decision. FinTech will look into the future and make decisions resulting in better asset



quality, thereby improving the health of the financial system. This is possible through greater availability of machine-readable data through a) increasing of the financialization economy and b) increasing digitization of the financial system.

Again, AI/ML-powered systems are going to complement human judgment in making decisions based on soft parameters like management quality and business environment, compared to solid parameters such as the balance sheet strength which are easier to evaluate. This will help bankers proactively predict and mitigate risk rather than reacting to unfortunate (default) events. While AI has been a part of several products and solutions, its usage is going to exponentially increase in 2021. AI will leverage all the crucial data sources such as internal systems, historical data, external sources and assist the financial models in their self-learning phase.

Regulations have also been helpful, in terms of formulation of laws pertaining to customers' personal data (PDP-2019 in India), as well as reporting by financial institutions to authorities. We will also see an enhanced use of cloud enabled models."

*Jaya Vaidhyathan, CEO,  
BCT Digital, Bahwan CyberTek*



### RPA to help automate low-value efforts

"In 2021, we are likely to witness a rise in the use of 'serverless architecture', that will help in achieving high scalability at low cost, wherein tech companies can adopt a 'pay per use' model, which is becoming increasingly popular. Technologies such as Robotic Process Automation (RPA) will help automate low-value efforts including data collection, increasing adequate human resource bandwidth for high-value activities such as alternative data analysis. In 2021, geolocation, video and image data will gain prominence and become more mainstream in assessment and profiling of individuals who seek credit."

*Jatin Bhasin, VP- Product, Capital Float*



### Micropayments and neo-banks to go deeper

"Across the world with globalization and business expansion the demand for supply chain finance

has increased rapidly. Lack of scalable operations at lending institutes coupled with enhanced compliance regulations has created a shortfall in the supply of capital. However, the recent technological trends have enabled FinTech companies to bridge this gap significantly and create a wider and newer pool of opportunities.



In the era where everything is shifting to an all-digital access and completely sustainable, the new-age technology platforms are exactly making lives effortless. The entire supply chain finance process has already drifted towards paperless processes by utilizing digitally available credit and financial data on companies or individuals, coupled with intelligent machine learning models to run credit assessments.

Supply chain financing has evolved massively in the digital age, with technology boosting the connectivity within the existing trade networks and in bringing new trade networks together. More so, technology possesses the power to create seamless systems that can enable the suppliers, buyers, and financiers to process information faster and communicate in real-time, hence improving efficiency levels without augmenting the incremental cost per customer.

The future of tech inclusions in finance is chasmic and further embracing the sectors adjoined. Especially, digital/micropayments and neo-banks will go deeper and will offer financial inclusion to the under-served adding incremental GDP. And here on in boosting technological advancements, we at CredAble believe that decentralized provisions are the key to upgrading financial liquidity."

*Nitin Sharma, Chief Product Officer, CredAble*



### Need for embeddable banking marketplace to emerge

"Wearables: Wearable devices for payment transactions have started gaining popularity amongst millennials and Gen Zs. More devices like smart watches are expected to transform the digital payment experience of customers.

*Cloud-Based Banking:*



Most banks have started to move towards cloud-based banking. This transforms their cost-efficiency and enables them to provide digital experiences to customers by keeping their legacy model intact.

*AI & Voice:* As voice-based interactions start becoming more popular with consumers, banks will start offering increasingly large numbers of services on a voice interface.

*Embeddable Banking:* The need for an embeddable banking marketplace will emerge where

FinTech providers and banks can collaborate to deliver hyper-personalized experiences to customers. Embeddable banking will enable FinTechs to embed financial products and services of one or more banks into their apps and experiences.

*'Zero Trust' Security Model:* Conventional IT models are getting outdated making banks prone to cyber frauds. A new approach to combat this threat is the Zero Trust Security model. It is a security framework that secures the enterprise by removing implicit trust and enforcing strict user and device authentication throughout the network."

*Ramki Gaddipati, CTO & Co-founder, Zeta*

## Surge in Online Loans

"2020 caused a lot of upheavals to the FinTech industry. Many lenders had to completely stop lending once the lockdown was announced, and those who did lend or had loans already saw a sharp increase in their defaults. On the other hand, a lot of customers started to look out for digital lenders in this pandemic, not just out of a need for loans, but also to keep social distancing and avoid contact with people.

We even saw a change in repayment patterns from customers, as they become happier to pay later despite accruing interest, and to ensure their liquidity does not get affected they were paying only from their disposable cash as well.

We also saw a huge increase in smartphone penetration in 2020, led on by TikTok, and by COVID, as people were forced to stay at home. This led to the surge in customer need for online loans as they were newly introduced to a whole new world. 2021 will be a very unique year, with the economy getting back up on its feet. A lot of new mobile subscribers and



first-time internet users will look for services to excite them, and this is a boon for all the consumer brands. FinTech will benefit largely from these new consumers as the convenience will drive a lot of referrals and word of mouth.

We're already seeing UPI grow by leaps and bounds. With the government's continued push on digital payments, such as mandatory FastTAG for every vehicle, we'll see even more digital payments adoption as people begin to travel as COVID fades away.

*Amit Kumar, Founder, Galaxy card*

## SECTION 12

## WORKSPACE



### VR tech making decisions quicker

"Workspace Design involves everything from layout planning to material and furniture selection to services design. Many applications and tools are now available to advance the quality of designs being produced. SaaS based platforms such as Saltmine and Egenera are used to create conceptual designs.

These platforms allow designers to quickly produce conceptual layouts, 3Ds and walkthroughs in less than half the time when compared to traditional technologies. They are used primarily to give the conceptual understanding of the workspace before it can be executed. VR technology is actively utilized to give a holistic experience of the entire space instead of standard 3D renders. This helps in taking decisions quicker on the actual look and feel of the workspace premises. 3D modelling and printing technologies are being used to design and execute bespoke furniture items which can now be curated on the basis of a 3D model. IoT for service designs has changed the way workspaces are designed and controlled. Technologies are now available to control and monitor the entire air-conditioning systems via cloud based software. Similarly access controls to a facility or CCTV monitoring within an office can be designed and monitored remotely via cloud based technologies."

*Devanshi Patel, Head, Workspace Services, ANSR*





SECTION 13 MEMORY & DATA STORAGE 

**New CPU architectures, AI-ML growth**

“We are excited by the combination of growth drivers coming into alignment for the industry for 2021. These growth drivers include: economic recovery from the pandemic; new CPU architectures, which are enabling higher server content; cloud, AI and machine-learning growth; robust mobile demand driven by 5G; and strength in gaming and automotive.



**Mobile:** The smartphone market has been impacted by COVID, but in 2021, we expect a rebound in smartphone unit volumes, coupled with robust average capacity growth across both DRAM and NAND solutions. 5G handset volumes could grow to approximately 500M units in 2021, from around 200M units in 2020, and these 5G products feature higher memory and storage content to enable enhanced user experience.

**Datacenter:** The data center market continues to be a growth engine for Micron, and this year COVID-19 accelerated this growth, specifically in cloud. The market is expected to start its transition to DDR5 in the second half of FY21, and networking and 5G deployments, particularly in Asia, will drive healthy DRAM bit growth quarter-over-quarter.

**PC & Graphics:** Work from home trends continue to drive strong demand for notebooks, with pockets of non memory component shortages in the supply chain. We expect a resurgence in desktop PC sales after a weak 2020 due to pandemic-driven changes to customer buying patterns.

**Automotive Memory:** In 2021, Auto DRAM and NAND will continue to see robust demand for autonomous vehicles and even connected cars promise more features including in-vehicle infotainment, 4K displays, AI-enabled features like gesture recognition and natural language processing, we’re seeing an exponential increase in memory and compute demands. The modern automobile has more lines of code than any other application or operating system—more than Facebook, Windows 10, airplanes,

etc. In fact, the amount of compute performance needed for cars is reaching data center levels; in advanced driver assistance / autonomous driving, cars need hundreds of tera operations per second which is some of the highest levels of performance in the industry today, rivaling what you will find in data centers and servers. Given these trends, in 2021, we can expect to see automotive players increasingly turning to alternative options for low-power, energy-efficient memory and storage such as fast, high-bandwidth graphics memory and compact multi-chip packages.”

*Anand Ramamoorthy, MD, Micron Technology, India*



**Greater open-source-reliant composability adoption**

“According to Seagate Technology’s Rethink Data report, Data Growth and Data Sprawl are on the rise; the amount of new data created each year is growing at a CAGR of about 26%. By 2025, 44% of data created in core and edge will be driven by analytics, AI, deep learning, and IoT devices. Also, 12.6ZB of installed capacity—HDD, flash, etc.— will be managed by enterprises and cloud will handle 51% of this capacity.

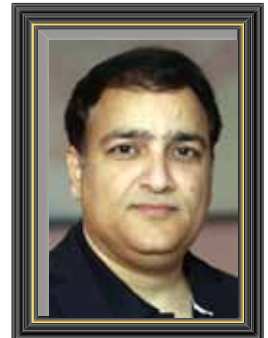

The development of IoT, AI, 5G, and edge will drive rapid adoptions of highest-capacity HDDs, with the anticipated 50TB HAMR HDDs to ship by 2026, and edge-to-cloud mass-storage platforms with sustained TCO advantages. Energy and cost-efficient innovations will also increase. Technology companies will continue improving open architecture to unify different resources, developers, open networks, storage, and computing solutions, and support DevOps. There’ll also be greater open-source-reliant composability adoption to seamlessly deploy and redeploy resources that can be streamlined and automated.

As businesses embrace distributed deployment models, focus on data encryption and hierarchical storage – in flight and at rest – is likely to increase. Object storage will be the de-facto standard for capacity storage for quick augmentation, displacement and scaling of data.”

*Sameer Bhatia, Director APAC, Consumer Business Group & Country Manager SAARC & India, Seagate Technology*



# Subscribe To PCQuest To Know More About Latest

- Tech Products
- Gadgets
- Product Reviews

Digital Subscription  
also available on  
Magzter, Readwhere,  
Readly, Wink &  
Paperboy.

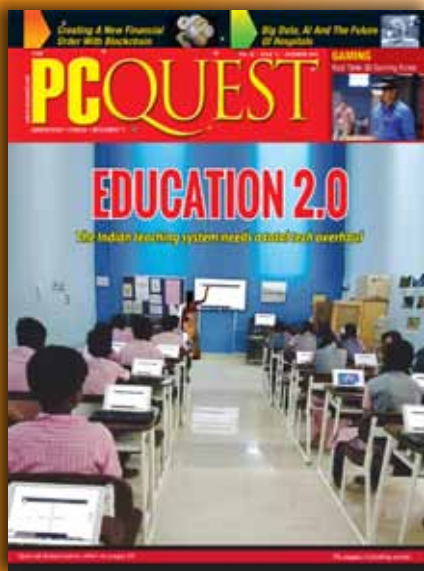

PCQUEST is available now for free download during Corona Virus Lockdown. Please go to our website [pcquest.com](http://pcquest.com) and download the digital copy of the latest issue of PCQUEST

## 4 EASY WAYS TO SUBSCRIBE

**1. Visit:** [subscriptions.cybermedia.co.in/pcquest.aspx](http://subscriptions.cybermedia.co.in/pcquest.aspx)

**2.** Through Cheque/DD in favour of '**CyberMedia (India) Ltd**'

**3. Bank Transfer via RTGS/NEFT**

Bank Details: ICICI Bank Limited, A/c no. 017705000132, Branch & IFS Code: Gurgaon, ICIC0000177

**4. Call:** 0124-482-2222, +91-9810499208

For any subscription related query please email : [rsepcquest@cybermedia.co.in](mailto:rsepcquest@cybermedia.co.in)

# Yes!

## I want to subscribe to PCQuest



### Subscribe to Digital Edition @ ₹1300

Period	Issues	Print Subscription Rate		Digital Subscription Rate
		New Subs.	Renewal	
<input type="checkbox"/> 1 Year	12	₹1500/-	₹1350/-	₹1300/-
<input type="checkbox"/> 2 Year	24	₹3000/-	₹2700/-	₹2340/- Save 10%
<input type="checkbox"/> 3 Year	36	₹4500/-	₹4050/-	₹3120/- Save 20%

or Subscribe online: [subscriptions.cybermedia.co.in/pcquest](https://subscriptions.cybermedia.co.in/pcquest)

Please tick your subscription choice above, fill the form below in CAPITAL LETTERS and mail it to us at [rse@cybermedia.co.in](mailto:rse@cybermedia.co.in)

I want to avail premium service of receiving my subscription copy by courier. Tick which ever is applicable.

₹500/- 1 year,  ₹950/- 2 years,  ₹1400/- 3 years

Name: Mr/Ms \_\_\_\_\_ Date of Birth: 

M	M	Y	Y	Y	Y
---	---	---	---	---	---

Organisation: \_\_\_\_\_ Designation: \_\_\_\_\_

Delivery Address: \_\_\_\_\_

City: \_\_\_\_\_ State: \_\_\_\_\_ Postal Code: 

--	--	--	--	--	--

Mob [+]: 

--	--	--	--	--	--	--	--	--	--	--	--

 Tel: 

--	--	--	--	--	--	--	--	--	--	--	--

 Email [+]: \_\_\_\_\_

I am paying ₹ 

--	--	--	--

 by DD/Cheque No.: 

--	--	--	--	--	--	--	--

 Dated: 

M	M	Y	Y	Y	Y
---	---	---	---	---	---

Payable at (specify bank and city) \_\_\_\_\_

OR

Please Remit for ₹ 

--	--	--	--

 Through RTGS/NEFT to our A/C details given below:

Bank Name: ICICI Bank Limited A/c No. 017705000132, Branch & IFS Code: Gurgaon, ICIC0000177

[+] Essential fields

Signature \_\_\_\_\_ Date: 

M	M	Y	Y	Y	Y
---	---	---	---	---	---

 Subscription No. (for renewal) \_\_\_\_\_

Order form can be mailed with payment (cheque/DD) to:

Sarita Shridhar, Cyber Media (India) Ltd, Cyber House, B-35, Sector 32, Gurgaon - 122001 Tel: 0124 - 4822222, 91-9810499208

Terms & Conditions: \_\_\_\_\_

• This offer is valid for a limited. • Rates and offer valid only in India. • Please allow 4-6 weeks for delivery of your first copy of the magazine by post & 8-10 weeks for delivery of your assured free gift. • Send crossed Cheques in favour of Cyber Media (India) Ltd. • Please write your name and address on the reverse side of the cheque or DD. All outstation cheques should be payable at par. • Cyber Media (India) Ltd. will not be responsible for postal delays, transit losses or mutilation of subscription form. • Cyber Media (India) Ltd. reserves the right to terminate or extend this offer or any part thereof. The decision to accept or reject any or all forms received is at the absolute discretion of the publishing company without assigning any reason. • Please include pin code for prompt delivery of your copy. • In case payment is through credit card, date of birth must be mentioned. • Request for cancellation of subscription will not be entertained once the free gift has been dispatched. • All disputed shall be subjected to Delhi jurisdiction only.

# HOW TO CHOOSE A TABLET FOR STUDENTS?

Choose the best tablet for your child, which can become a companion, not a burden

Ashok Pandey  
ashokpa@cybermedia.co.in

**T**he pandemic has changed everything, now students are attending their classes online. This becomes a challenge to make parents as few are using a smartphone, PC/laptop and other devices. A lightweight and portable tablet with a large screen and decent processing power would suffice the needs of students.

Here are a few terms that will help you choose the right device –

## Performance

For online classes, you actually don't require a high-end table. As like smartphones, you have similar processor choices. For online classes, your child will use video conferencing applications, and media players to re-watch the recorded class. They can do some internet surfing, and when they are free might enjoy playing some games as well. So you need a processor that can cater to all these requirements. You can go with an Octa-core processor with 2 or higher GHz clock speed.

But here you can get a tablet with 2 GB of RAM is enough for students, but there are devices with up to 6 GB RAM. You can choose one as per your budget.

## Storage

Usually, tablets come with 16 GB storage which could be enough. However, I would recommend having a minimum 32 GB storage so you never face any challenge while storing documents and other contents.

## Display

Tablet's screen size can range from 7 to 11 inches. Don't go for a huge screen as it would be massive in weight and difficult to manage for your child. You need a large screen, below 10-inches, with high resolution, not less than FHD (1080p). This would help your kids to understand whatever is visible on-screen during the class. With a lower resolution, they might find it difficult to read or understand.



## Connectivity

Almost every tablet comes with Wi-Fi connectivity, while a few come with Wi-Fi + 4G. If you have Wi-Fi connectivity at home then you can choose Wi-Fi only tab, but remember in case you are out of your house, then a Wi-Fi dongle would be required, else your child won't be able to join the class or browse contents available online.

Choosing a Wi-Fi + 4G connectivity will give you freedom to switch between any of them.

Wi-Fi only tablets are cheaper than Wifi+4G tabs, so your budget could be a factor to decide which one you would buy.

## Weight

As I mentioned earlier, the large screen would make your device massive in weight, so you need a lightweight lab. It would be better if you can get a stand or cover that can act as a stand while your kid is attending his/her online class.

But you cannot deny the fact that either your kid or even you would use handheld tablets to use it. So, using heavyweight tabs for a longer time would be tiring.

## Battery

You don't want to charge any of your devices so frequently. A tab with above 4000 mAh battery could be the right choice. And remember, with higher would be better, however, it will add weight to your device as well.

## BEST 6 TABLETS FOR STUDENTS

### Apple iPad (Wi-Fi, 32GB)

**Price:** ₹29,900

This tablet is not for everyone, but if you are the one who prefers Apple products only, then go for iPad. Your child will love to perform various activities with this powerful and elegant tablet. Whether attending classes or playing games, the tablet will run smoothly without any performance lag. It comes with a fingerprint sensor to keep your data safe and secure.



### Lenovo Tab4 8 Plus Tablet

**Price:** ₹15,999

With the 8-inch screen, this tablet is the perfect table for online classes. You get ample of storage, 64 GB, to store all the study materials. Your kid can attend their online classes without any lag or jitter as the Snapdragon processor ensures smooth functionality. It also supports 4G SIM to enjoy high-speed internet connectivity.



### Samsung Galaxy Tab A 10.1

**Price:** ₹13,999

Your kid will enjoy learning new things on the bright and colourful displays of the Galaxy Tab A. Powered with Exynos processor, the table can handle all the collaboration apps to join the online classes.



### Honor MediaPad T3 10

**Price:** ₹14,999

The table is powered by Kirin 710 Octa-core Processor coupled with 4 GB RAM, meaning your child can run all the applications required for his education. It has 8-inch IPS FHD screen producing bright colours plus with an Eye Care mode you can protect your kid's eyes from blue rays of the screen. Additionally, it supports 4G connectivity for uninterrupted learning and fun



### HUAWEI MediaPad T5 Tablet

**Price:** ₹14,999

The MediaPad has 10.1-inch FHD (1080P) display for crisp and clear viewing experience. Your child will enjoy attending classes on this. The powerful octa-core processor gives great performance while smoothly running multiple applications simultaneously. This is a light and durable laptop elegantly designed with a metal body. Most importantly, it has an eye-comfort mode that reduces harmful blue light to create healthy reading conditions.



### iBall iTAB BizniZ Mini Tablet

**Price:** ₹10,290

A decent table at the budget price. It is equipped with full HD 8 inches IPS display for better quality video output during the online classes of your kids. It has 2 GB RAM which is sufficient to run video meeting apps. It also supports 4G SIM for uninterrupted connectivity.



# HOW TO CHOOSE THE RIGHT SMARTPHONE

Numerous brands and plenty of choices. Choosing the best fit smartphone is becoming more challenging, but don't worry, you can find a perfect match quickly and easily.

Ashok Pandey  
ashokpa@cybermedia.co.in

**W**e saw rapid tech innovations in smartphones in the past few years. When we look back a few years, single high-res camera phones were available, and now we have quad camera setup. We used to be looking at IPS, Retina and AMOLED screens, now we have foldable smartphones. Nowadays, the smartphone is powerful enough to handle various tasks, which were only possible with PCs. These are just a few, with added features there is always a question as to which smartphone should one buy and for what price.

There are several aspects to consider while choosing a smartphone. Here's what you should look out for.

## Performance

Before choosing a smartphone, look for following specs for a hassle-free experience –

**Mobile Processor (CPU):** Whatever you will do with your phone, the processor will be handling them. The smartphone processor, also known as the chipset or the SoC, is essentially the brain of the system. The modern SoCs are also come equipped with AI capabilities. The SoC is not only responsible for the seamless functioning of your phone, it also enhances other factors including image processing.

Majorly there are four mobile processor manufacturer - Qualcomm, MediaTek, Apple and Samsung.



Qualcomm announced its new 5G capable CPU in May 2020, Snapdragon 768G 5G with clock speed up to 2.8GHz. And in September 2020, Qualcomm unveiled the Snapdragon 750G processor, designed to bring 5G support for low-latency mobile gaming.

MediaTek announced Dimensity 800U, an ultra-connected dual 5G chip that balances immense CPU speeds with an efficiency-focused design. The latest addition to the Apple CPU family is A14 Bionic, a 64-bit ARM-based SoC.

**RAM:** The RAM in a smartphone is closely associated as to how its performance would be. Having more RAM gives you freedom for switching between apps or frequently used app and more RAM results into better multitasking.

If you want to play heavy graphics-intensive games then you need to choose a phone with 6 GB

or higher RAM. Smartphones running on Android OS need updates frequently on several apps or the OS. In such devices 6 GB RAM is fine, but 8 GB is better. However, some smartphones are installing a whopping 12-16 GB of RAM, which isn't useful unless you are going to do multitasking with over 20 apps at the same time.

### Camera Quality

In 2020, multi-cameras are the norm, you usually get a primary lens which sports the highest MP count, a portrait lens, and a wide-angle shooter. A few manufacturers also adding lenses like a macro lens, ToF (Time of Flight) sensor, and colour filter lens.

Don't go blindly for the idea that more megapixels will give you better pictures. Instead, look for phones that pack good camera optics like aperture, speed and other relevant features. A larger aperture camera sensor means you can capture decent shot indoors without using the flash. Look for optical image stabilization to reduce blur and improve low-light performance. Good photos are a result of adequate megapixels, good lens and sensor technology, as well as high-end processor chipsets.

### Operating Systems

The most popular OSes are Google's Android and Apple's iOS. Android is the most popular and powerful OS and is available on a wide price range of smartphones. It is an open-source OS, which means it's easy to customize with widgets, launchers, your choice of keyboard and more. You can opt for Android if you enjoy customising your phone to your heart's content

If you like a simple and powerful OS, then iOS is the right choice for you. With iOS, you also get constant software updates and is supported for a more extended period. iOS has some limitation, for instance, you can't use launchers to completely change the look of your phone.

However, iOS comes with a plethora of advantages as well, such as regular software updates, FaceTime, iMessage, and the biggest of all, minimal bloatware, and no adware.

### Display Quality

How you interact with your phone? Its display that allows you to perform any task. The display is one of the most important aspects to consider. The smartphone industry rotates around various names to describe the viewing experience on your smartphone screen viz. LCD, LED, OLED, AMOLED, S-AMOLED, Retina, Super Retina XDR, etc.

The ideal option must depend on your usage. If you want to watch movies, play games AMOLED or higher will be a better choice giving a higher contrast ratio, and rich colours. On the other hand if web surfing, document viewing is more important to you than LCDs and Retina Displays or higher will be more preferable offering crisper texts and making it easier to read on-screen for long periods.

Another important factor is the display size. Earlier, the screen size was 3 to 5.5 inches, but now most of the device come with displays ranging from 6 to 7 inches. Depending on your content consumption, you can get a small or large screen.

The larger screen means holding the device in a single hand would be difficult! It was tomorrow's story, now phones have taller screens. The aspect ratio is also increased from 16:9 to 21:9. So you should buy a smartphone with an 18:9 aspect ratio right now as most of the content on different platforms is tuned towards that aspect ratio too.

The display resolution plays an important role, FULL HD is good for video viewing and gaming. Choose QUAD-HD for an amazing experience with applications like VR gaming, multi-window apps.

Another important aspect of the display is the protection used. The industry standard tough glass is manufactured by Corning, which have their flagship line of glass known as the Gorilla Glass. Most smartphones come with this protection, so if you are buying a smartphone, make sure that it comes with Gorilla Glass protection that would prevent the display from scratching and even protect against minor falls.

### Storage

Go for as much internal storage as possible. We have games that take around a 1 GB or more of space like Asphalt and Dead trigger that requires having 1 GB or higher space. If you are a power user, then no less than 128 GB would suffice your needs. This is because of images and videos, which you will store on the device, occupy a huge space.

### Battery

While smartphones are growing more advanced and are becoming as powerful as laptops but with high-definition screens and professional camera technology they're still limited by power. Measured in mAH, go for higher numbers to give you more talk time, and enough juice to run your music and videos

Do check, if your phone supports fast charging. With quick or fast charging, you can charge your phone in 40 min from 0 to 100%, saving your time.

## 6 BEST BUDGET PHONES

### Realme C11

**Price:** ₹7,999

The Realme C11 is an entry-level smartphone with the MediaTek Helio G35 under the hood. It has an HD LCD display, a giant 5,000mAh battery and a dual-camera setup at the back. It has only 2GB of RAM, so you may find some performance issue with high-graphics intensive apps.



### Redmi Note 9 Pro

**Price:** ₹12,999

The phone is powered by Qualcomm Snapdragon 720G processor, 4GB RAM and 64GB storage, which makes it capable of handling most of the apps. Equipped with 48MP primary quad-camera based array, which is a pretty good combination at this budget.



### Vivo U10

**Price:** ₹9,999

The Vivo U10 runs on the capable Snapdragon 665 SoC that was initially made for mid-range smartphones. The SoC in itself gives a big boost in performance thanks to fast 2.0GHz performance cores and an Adreno 610 GPU. It has a large 5000mAh battery that tops up quickly thanks to an 18W fast charger. There is a triple camera setup at the back which includes a 13MP primary camera, an 8MP ultrawide camera and a 2MP depth sensor. The phone also rocks an 8MP selfie shooter on the front.



### Samsung Galaxy M21

**Price:** ₹13,999

The M series of Samsung is quite popular. The Galaxy M21 is more than an average device at this price. It offers impressive performance and better cameras at roughly the same price. Exynos processor coupled with 4 GB RAM gives you enough power run multiple apps. The triple camera setup lets you click outstanding images.



### Motorola One Macro

**Price:** ₹9,999

As the name suggests, it sports a macro camera. The smartphone is powered by the MediaTek Helio P70 which is good enough for the usual tasks of browsing, shooting and sending emails, but not so good at gaming. It packs a 4000mAh battery that lasts for one day and a half on normal to heavy use.



### Realme Narzo 20 Pro

**Price:** ₹13,999

The smartphone is packed with MediaTek Helio G95, 6 GB RAM and 64 GB storage making it powerful enough to play games and do multitasking without any lag. It has amazing 90Hz LCD display and 4500 mAh battery with fast charging. For photography, it has 48 MP quad camera setup.





## 6 BEST MID-RANGE PHONES

### Motorola One Fusion+

**Price:** ₹17,499

The most powerful mid-budget smartphone is powered with a Snapdragon 730G, along with 6 GB RAM. This is capable to deliver smooth frame rates while gaming and also bring in some Snapdragon Elite Gaming features found in flagship phones. Packed with 64 MP quad-camera setup, you can capture beautiful images even in low-light conditions.



### Realme X3

**Price:** ₹22,999

The affordable flagship phone comes equipped with a Snapdragon 855+, packed with 8 GB of RAM and 128 GB of storage. It also uses the 7nm FinFet technology and clocks up to 2.96 GHz to facilitate a powerful performance. At the back, it has a 64 MP quad-camera setup that's quite versatile with a 13MP telephoto lens, an 8MP ultrawide lens and a 2MP macro lens.



### Samsung Galaxy M31s

**Price:** ₹19,499

Looking for a powerful device with an equally massive battery! Samsung Galaxy M31s has a 1.7GHz+2.3GHz Exynos 9611 octa-core processor coupled with 6 GB RAM and a giant 6000 mAh battery suitable for kinds of heavy users. But don't worry about charging time, it has fast charging capabilities, saving your time and giving freedom to play for a longer time. The phone also sports an FHD+ AMOLED display for maximum power efficiency. For the best photography experience, it is packed by Quad camera setup – 64 MP + 12 MP + 5 MP + 5 MP.



### Asus 6z

**Price:** ₹30,999

Innovative flip camera stands this phone out of the crowd. The rear camera flips over to become the front offering the same sensors for both your landscapes and selfies. The flagship phone is equipped with the Snapdragon 855 coupled with up to 6 GB RAM and 128 GB storage.



### Redmi Note 9 Pro Max

**Price:** ₹18,499

Another powerful device in the segment, Redmi Note 9 Pro. It gets a 64 MP quad-camera setup at the back, a 32MP selfie camera and faster 33W charging. It comes with a large 6.7-inch LCD display with a punch-hole camera. It's powered by the Snapdragon 720G along with 6 GB RAM and 64 GB storage.



### OnePlus Nord

**Price:** ₹29,999

The OnePlus Nord offers a smooth and fast experience without spending much. All thanks to the Snapdragon 765G under the hood, the phone performs without a hitch. There are also over 300 software optimisations in place and combined with a 90Hz display. Click amazing shots, day and night, with quad-camera setup 48+8+5+2 MP. The front holds dual selfie shooter 32+8 MP camera with 4K video capture at 30/60 fps and 1080 video capture at 30/60 fps.



## 6 BEST PREMIUM PHONES

### iPhone 11 Pro Max

**Price:** ₹1,17,100

It is among the most premium smartphones you can buy today. The premium phone comes with Apple's Super Retina XDR display which is an OLED display tuned to offer vibrant colours. For the first time, Apple included a triple camera setup at the back including three 12 MP lenses - wide, ultrawide and telephoto lens. You can store your beautiful memories in 4K videos at 60 FPS along with slow-motion and even comes with a dedicated Night Mode.



### Motorola Razr 5G

**Price:** ₹1,24,999

The compact and fashionable premium phone comes with the flip design. The next-gen Motorola flip phone is packed with Snapdragon 765G Processor, 8 GB RAM and 256 GB ROM. It has a single 48 MP rear camera and 20 MP front camera. When closed, the tiny phone has a screen on the front for notifications and selfies, etc. When open, it becomes a large 6.2-inch phone.



### Samsung Galaxy Z Flip

**Price:** ₹83,999

The flip phone from Samsung got some improvements. The new Galaxy Z Flip comes with a bendable display, when closed, tiny phone and when open it becomes a full-fledged smartphone with a 6.7-inch screen. The flagship smartphone has a powerful Snapdragon 855+ processor along with 8 GB RAM. It has a dual 12 MP camera at the back and a 10 MP selfie shooter on the front.



### Samsung Galaxy Note 10+

**Price:** ₹69,999

One of the best premium flagships phone comes with the S-Pen inside which is perfect for doodling or taking notes or making edits on a document. Packed with an excellent quad-camera setup that includes a regular 12 MP wide, 12 MP telephoto, 16 MP ultrawide and a ToF 3D sensor.



### Huawei P30 Pro

**Price:** ₹58,999

This is a perfect companion for photographers. The premium smartphone has one of the best camera made by Leica. The best camera smartphone has a custom 40 MP camera sensor, an 8 MP periscope telephoto lens and a 20 MP ultrawide lens along with a ToF 3D sensor for portraits.



### OnePlus 8 Pro

**Price:** ₹54,999

The flagship smartphone rocks a large 6.78-inch AMOLED display with 120Hz refresh rate. Packed with Snapdragon 865 SoC, the phone has a 48 MP quad-camera setup at the back. It supports 30W fast wired and wireless charging as well as rated IP68 water and dust resistant.



# TELECOM LEADERSHIP FORUM

20th ANNUAL MEETING OF THE TELECOM ECOSYSTEM  
EMPOWERING LEADERS IN TELECOMMUNICATIONS

## Bedrock of Digital Economy

10 February 2021 | 09:30 – 05:30 PM

Follow us: [@VnDIndia](https://twitter.com/VnDIndia)

[tfindia.in](http://tfindia.in)

Voice&Data has been awarding the major leaders of the Industry for their transformation journey they undertook in uplifting the services with tech & innovation, strategy and showed impeccable leadership in the organisation.

Jury Meet: 18<sup>th</sup> December 2020

Last day for nominations : 15 December 2020

Nominations open for 20<sup>th</sup> edition Telecom Leadership Awards in three categories.

**Telecom Person of the Year**

**Pathbreaker of the Year**

**Lifetime Contribution Award**

### Jury Members



**Dr. R S Sharma**  
Former Chairman, TRAI  
( Jury Chair )



**Manoj Kohli**  
Country Head, Softbank India  
( Jury Co-Chair )



**Dr. Anand Agarwal**  
Group CEO, STL  
( Jury Co-Chair )



**Prof Veezhinathan Kamakoti**  
Dept of Computer  
Science & Engineering  
IIT Madras



**Sanjay Kaul**  
President Asia Pacific &  
Japan. Service Providers  
Business, Cisco



**N K Goyal**  
Chairman emeritus, TEMA  
President, CMAI



**T V Ramachandran**  
President  
BIF



**Lt. Gen Dr. S P Kochhar**  
Director General  
COAI



**Manu Jain**  
Vice President, Xiaomi &  
Managing Director  
Mi India



**Pradeep Gupta**  
Chairman  
Cybermedia Group

You can also send the nominations to [ravik@cybermedia.co.in](mailto:ravik@cybermedia.co.in) and [shubhendup@cybermedia.co.in](mailto:shubhendup@cybermedia.co.in)

For marketing & alliances, write to  
[rajivp@cybermedia.co.in](mailto:rajivp@cybermedia.co.in)

Kindly send your nominations to  
[ravik@cybermedia.co.in](mailto:ravik@cybermedia.co.in)

# HOW TO CHOOSE THE RIGHT PRINTER?

These are the key requirements you have to keep in mind for choosing the right printer...

Ashok Pandey  
ashokpa@cybermedia.co.in



Choosing a printer for your home or business isn't easy. There are multiple factors which you should keep in mind before making your decision. If it's for home use then you need to look at different aspects and if it is for your business then you need a printer that can fulfil many office printing requirements as well as features.

For your home, you can look at the budget and the features like multi-function, wireless connectivity, etc. A small business with its respective requirement can consider buying a business printer with a larger footprint. However, nowadays most of the compact and multifunction printers are more popular among businesses. If space is not a constraint for you in the office, then size becomes secondary.

Here are some key features that you should consider before making your choice –

## Laser or Inkjet?

Inkjet printers are the most popular among consumers when buying a printer for home. The reason is quite obvious as the front investment is low and they are compact in size. On the other hand, lasers are the preferred choice over inkjets in office, especially if you need to do volume monochrome printing.

Although the initial investment in buying a laser printer might be high when compared to an inkjet, the overall running cost throughout its life is much lesser.

## Laser vs Inkjet – Technology

A laser printer uses a non-impact photocopier technology, in which keys don't strike the paper. A laser beam reproduces the image and prints it on

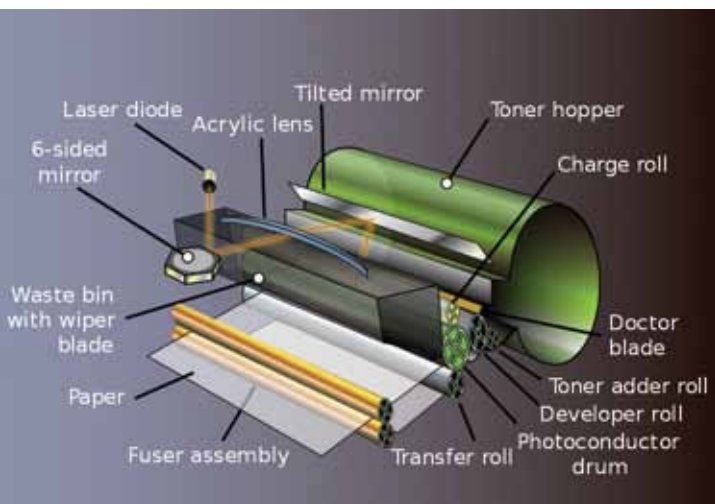

the drum. This laser light runs side to side over the drum and the negatively charged toner (cylindrical component) that allows the laser to pick up ink in a powder form through static electricity. Then toner and paper meet to leave a permanent impression.

Inkjet printers spray tiny ink droplets onto the paper. In this, the printer employs a moving print head, filled with colour and black ink. This head goes side to side and spray the ink bubbles onto the documents being printed.

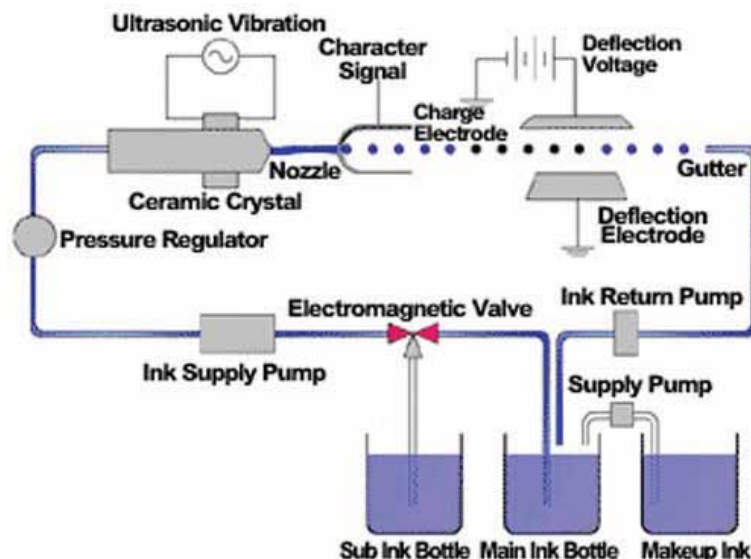

While most of the functions will be similar in both inkjet and laser printers, the two different technologies achieve printing results in very different ways.

### Laser vs Inkjet – Print Quality and Speed

Laser printers produce fine quality of text and

graphics, making it an ideal choice for document printing.

Photograph output is of moderate quality with laser, while, inkjets produce sharp and vivid images. Inkjet printers outshine when you want to print on a wide variety of media like vinyl, plastic, cloth, etc.

Compared to a laser printer, inkjet is slow when it comes to printing black and white text pages. Enterprise laser printers can print up to 80 pages per minutes. Inkjets are slower compared to laser. This is one of the main reasons to choose a laser printer over inkjets for business.

### Laser Vs Inkjet – Cost Per Page

The upfront cost of the printer can be a major factor in choosing the right printer for you. But when it comes to choosing a printer for business, cost per page matters more than ownership cost. Inkjet printers are less expensive compared to the laser one, as inkjet technology is less complex thus the cost of manufacturing is also lower.

On the other hand, the printing cost of inkjet is higher than the laser. The refilling and replacing the cost of the toner on a laser printer is lesser than that of a cartridge refill in an inkjet. Plus, as compared to inkjets, you can print more pages with a laser. You can calculate the cost per page using the formula – cartridge price /page yield = cost per page.

Depending on the nature of your business, you can print multiple documents on a daily basis. The cost per page of a laser printer will be less expensive compare to inkjet, so we recommend to buy a laser printer for business to save extra every month.

There's a new class of inkjets available nowadays that come with ink-tank technology. Their cost-per-page is much lower than traditional inkjets. Plus, they allow Wi-Fi and mobile connectivity, meaning you can fire a print from your mobile phone over Wi-Fi. So if you need colour in the home or office without the added high printing cost, then these devices are worth exploring.

### Single or Multi-function?

Home or office, most of the time, you majorly print documents, but nowadays, you also often need to scan documents or copy them. This is where buying a multi-function laser printer should be your choice.

For business, a few can argue of having a separate scanner, which can offer OCR and other scanning capabilities. Modern MFPs also comes with such features and functions with a similar or higher scan

resolution of 1200 dpi.

So, whether home or business, prefer to buy a multi-function printer over a single function printer.

### Paper handling

The A4 size of normal print paper is common in almost everywhere – home or office. Home users can buy A4 printer while depending on your business requirement, you can choose the paper you want to use. Buy a printer that supports the desired paper size and quality. As earlier, we talked about photo prints, where inkjet is better than laser, so if you want to print a large size photo, then consider an inkjet that supports larger paper size.

For different size of document printing, you can buy a laser printer, just ensure to select a printer capable of printing that size of paper. For instance, there are multiple paper size A4, A3, B5, Letter, Legal, Tabloid, etc.

### Easy to refill

Whether its inkjet or laser, refilling the ink or toner is a challenge. However, ink-tank printers are easy to refill. Moreover, they can hold the ink for a long time without letting them dry compare to ink cartridges.

Nowadays, even laser printers let you quickly refill the toner. You can easily get a toner which can be used to push to refill your laser toner.

### Duty Cycle

What sort of load is your machine going to handle? For home printing, the requirement will be much lower, so you can ignore this, but for a business, you should look at the duty cycle of the printer.

Depending upon your nature of the business, your print requirement could be up to 1000 page per month or up to 20,000 pages per month. You should look at the duty cycle of the printer and choose the one that can support your requirements.

### Wireless connectivity

Having a wire here and there can make your home and office messy. When you have a technology like WiFi, then it's better to get a printer that supports wireless connectivity. A wireless printer lets you print from anywhere. You just need to configure the printer over your home or office WiFi and you are ready to print or scan from anywhere.

Lastly, you could also opt for network laser printers, which can connect to the network and provide software that can do advanced monitoring of your print volumes, and give better security, etc.

## TOP 6 HOME PRINTERS

### Canon Pixma E477 All in One wireless Ink Printer

**Price:** ₹4,999

A multipurpose device that not only provides a great value for money but also has the flawless performance that makes it a perfect device. Connect your devices with the printer through the Canon Selphy app and print directly from the smartphones and tablets.



### HP DeskJet 2778 All-in-One Ink Advantage Wireless

**Price:** ₹6,099

HP DeskJet 2778 printer is one of the best printers for home users. The value for money printer is efficient enough to deliver the best quality prints and the after-sales services you can always rely on HP. The multifunctional printer has various connectivity options including Wi-Fi, App, and USB for a hassle-free printing and scanning experience.



### HP DeskJet 4729 All-in-One Ultra Ink Advantage Wireless

**Price:** ₹8,999

This is a compact and easy to handle printer for your home. Along with a great design and brilliant brand value, this printer has a great set of features that are hard to find in this range of printers. HP DeskJet 4729 comes with an LCD screen, easy to use control panel, manual duplex printing, and efficient cartridges with a great page yield of 750 pages. It offers various connectivity options that include USB, Wi-Fi, and App.



### Canon Pixma G2012 Colour Multi-Function Ink Tank

**Price:** ₹10,499

Consumers looking for an easy to use, reliable, and affordable printer that performs flawlessly in every condition, then this is one of the perfect options available. The printer comes with a familiar signature design and easy to use control panel. The printer supports manual duplex printing and you can easily get the pro level print quality (4800x1200dpi) from this.



### Epson Ecotank L3152 Multi-Function Ink Tank

**Price:** ₹13,699

Epson L3152 is an all-in-one printer housing an integrated ink tank with a design facilitating spill-free refilling. It has a flatbed scanner that enables functions like copy and scan. A combination of features like 5,760 x 1,440 dpi resolution, borderless printing, and a page yield of 7000 prints make it an excellent option for all-purpose use. Besides the conventional Wi-Fi, Wi-Fi Direct and USB connectivity options, it also supports mobile apps.



### HP Smart Tank 515 All-in-One Wireless Ink Tank Printer

**Price:** ₹14,699

HP Smart Tank 515 AIO looks similar to any other HP AIO printers.

It is powered by a new sensor-based Ink Tank technology that alerts the user before the ink runs out. The printer has a compact design so you can set it up at your desk. It also features the Wi-Fi Direct capability that lets the smartphone connect to the printer without the need for an internet network. It is one of the best MPF available in the market for a home and small office.



## TOP 6 BUSINESS PRINTERS

### HP OfficeJet Pro 8026 All-in-One Wireless Smart Colour Printer

**Price:** ₹9,999

The All-in-One printer is perfect for small and medium business. It offers wireless connectivity for uninterrupted printing experience to everyone. Supports different page sizes including—A4, A5, A6, B5, C5, C6, DL envelope. It supports duplex printing and also has voice-activated printing feature which works with Alexa & Google Assistant. Interact and control the printer directly using the touch screen to complete your print, scan, and copy jobs. The printer has best-in-class security to help protect devices, data, and documents. No need to check the ink level manually, the app lets you do that as well as order a new one.



### Epson M2140 EcoTank Monochrome All-in-One



**Price:** ₹17,649

The compact printer has a new tank design integrated into the printer to allow the printer to have a small footprint. Additionally, the unique bottle nozzle enables spill-free and error-free refilling. At just 12 paise per mono printout, and the fast print speeds of 39ppm for draft and 20ipm (simplex) for standard prints.

### Xerox WorkCentre 3025V\_NI Printer



**Price:** ₹18,400

If you are running a business where you need to print on different paper with various colour adjustments, then WorkCentre 3025 is perfect for you. You can customize the paper size as per your printing need. You can do printing like Booklet, Watermarks, etc. Along with colour adjustment, the printer supports wireless connectivity and freedom to print from anywhere using Apple AirPrint, Google Cloud Print, etc.

### Canon PIXMA TR8570 All-in-One Wireless Inkjet Color Printer



**Price:** ₹21,885

This compact machine can easily fit into even the smaller spaces. Equipped with a 10.92cm intuitive colour touch-screen display panel, making operation smooth and simple. You can easily accommodate different paper sizes/types simultaneously as it has two paper trays. Supports duplex printing to save your time and resources. Operate the printer directly using the touch screen or use your mobile device to print or scan from anywhere.

### HP Neverstop Laser Multi-Function Direct Wi-Fi 1200w



**Price:** ₹18,999

The laser printer is built for non-stop printing needs. The multi-function printer comes with Wi-Fi, and USB 2.0 connectivity. The print cost is as low as 29 paise per page. Having a printer that really never stops, even if your toner is empty, it would take only 15-second to restore toner levels without any mess. The ground-breaking design of our toner reload kit helps you get back to printing in seconds.

### Xerox B215



**Price:** ₹26,899

The all in one printer has all of the essential features a business might need including duplex printing, Wi-Fi Direct and a port for a USB flash drive. Having a touchscreen, it enables users to print or scan directly to your USB drive. Connect your printer to the office network and freely print through your mobile device from anywhere using any of the services like Apple AirPrint, Google Cloud Print, Mopria and Xerox Print Service Plug-in for Android. With all the flexibility and up to 30 ppm print speed, it is a viable choice for your business printing needs.



# EVERYTHING YOU NEED TO KNOW BEFORE BUYING THE BEST SPEAKER

What are you looking for? Home theatre or portable? Both have their own set of features. To cope with the stressful decision, here are key suggestions to keep in mind while choosing a speaker

Ashok Pandey  
ashokpa@cybermedia.co.in



**T**he technology gives us the freedom to take our entertainment in our pocket – smartphones. In the same fashion, nowadays wireless speakers have become a part of our music need. Wherever you go, you can carry your music in your bag. The portable speakers let you enjoy music anytime and anywhere.

However, still a few prefer to be in their own world and use headphones to listen to the music. While some don't prefer the small speakers, they need a good set of speakers that can deliver awesome audio so they never miss even a single beat.

But before choosing your music partner you need to keep a few essential terms in mind.

## Wireless technology

**Bluetooth:** Bluetooth is the best wireless connectivity



option for all wireless speakers. The latest version is Bluetooth 5.2, which offers higher throughput and greater battery efficiency.

**NFC:** Apart from Bluetooth, you can also pair your speaker using NFC, another type of wireless technology for short-distance communication and



you will get to hear about it in some of the high-end speakers. The range is limited and you need to have both devices in close proximity.

NFC makes pairing easy over Bluetooth, simply tap the device to the speaker to complete the pairing.

**AirPlay:** Wi-Fi, a well-known technology for connectivity between different devices. Apple used the technology to develop AirPlay that allows wireless streaming of audio and video between devices over a Wi-Fi network. If you are using an iPhone, iPad etc, then you can buy a wireless speaker featuring AirPlay to stream music wirelessly.



Almost every wireless speaker comes with Bluetooth connectivity, but other technologies are not that common. The range of Bluetooth is up to 10 meters, while NFC works with Bluetooth and AirPlay with Wi-Fi. The NFC range depends upon the Bluetooth, however, the range of Airplay is significantly better than Bluetooth, so people with iOS devices would prefer that, but it comes at an extra cost.

A feature like Wi-Fi or WPS becomes critical if you want to set up a multi-room home audio system. However, keeping in mind the portable nature of the product, Bluetooth is sufficient enough to serve most of the purposes.

### Drivers

Most of the portable speakers will typically have a 40mm driver, which is a good size to start with. For home theatres, you want bigger drivers. The bigger is driver, the overall size of the speaker to increase too. The number of drivers and their placement also make a difference to the sound output. Many speakers come with a twin driver setup, which tends to be noticeably louder.

### Sensitivity

Have you ever considered the sensitivity of

the speaker or headphones? A speaker sensitivity expressed in decibels per milliWatt (dB/mW). This signifies the level of sound produced by the speakers in response to a 1mW signal. In Lehman language, more the sensitivity, better the output.

### Frequency Response (FR)

The FR range of an audio device depicts the output of a speaker. A human's listening range is 20 Hz to 20 kHz. A speaker's FR represents the range. Where a 20Hz of frequency produces very heavy bass, 20kHz would deliver a very high pitch sound (treble). For example, if a speaker's frequency response is between 20Hz to 200Hz – it would mean that this is a sub-woofer with heavy bass. If a speaker has a frequency range of 19kHz to 20kHz, then in all probability it will have a very high pitch sound. A speaker with a very high range would mean that the speaker has the capacity to throw all three: bass, treble, and vocals very clearly.

### Additional Features

Whether it is portable, home theatre, or headphones, additional features do matter while making a buying decision. Connectivity options, base ports or base radiators are key things to look at. Some might look at mic availability with the portable speaker to attend a call while with home-theatres karaoke to sing along.

### Durability and Build Quality

When choosing a portable speaker, you should check the levels of durability. If you spend time enjoying outdoor sports and activities, then look for speakers with dust-proof and shockproof design.

Also, speakers with a metal frame or casing are generally better than those with a plastic body. The best is wood for its durability, build quality and sound experience.

A portable speaker can also act as a power bank for your phone. This comes handy when you are in flight for longer hours or overnight camping trip. Wireless portable speakers feature a USB charging port that can even provide extra power to your smartphone or tablet. Do check their battery capacity, so do look for the charging time and battery life delivered on a full charge.

The most important thing to check in speakers – sound quality. Look for speakers that have a good balance of low frequency for strong bass and balanced middle, high frequency for a rich sound signature.

## 6 BEST HIGH-END MUSIC SYSTEMS FOR HOME

### Sony HT-IV300 Real 5.1 Home Theatre System



**Price:** ₹23,990

The Sony HT-IV300 comes with a receiver unit that looks like a DVD player. However, it's pretty compact and has a digital display at the front panel, and underneath that, a white LED light that turns on when you switch on the system.

The subwoofer is front-facing and drivers are built into a wooden cabinet with a metal grille at the front. It has NFC (Near-field communication) letting you connect your phone in just one tap (Bluetooth enabled).

With great sound quality, it gives you immersive sound experience.

### Bose Sound Touch 20 Series III Wireless Music System



**Price:** ₹26,910

It looks small, but actually, it produces ample sound. The high-end home theatre gives you various connectivity options including Ethernet cable, two USB port and auxiliary input. It also has a BOSE app, which is way too handy. You can do almost anything with the app.

With great sound and small footprint, this is perfect to enjoy the music.

### Yamaha 1840 Home Theatre System 5.1



**Price:** ₹31,000

From MP3 to any other audio format, your music experience won't suffer from frequency response. Yamaha's Compressed Music Enhancer employs sophisticated digital signal processing using exclusive algorithms to restore what was lost, so you will always get the best quality sound the way it should.

Place all the speakers at the front, the Virtual Cinema Front feature enables all five speakers to bounce the sound around creating the illusion of surround sound.

Whether you are enjoying the cricket world cup, your favourite movie or your best TV show we need a kickass system to keep us immersive. And Yamaha 1840 is perfect for all your music needs.

### Pioneer S-RS55TB 660W RMS 5.0-CH Home Theatre



**Price:** ₹34,990

The tall floor-standing speaker front speakers with vertical twin woofers, a centre speaker and surround speakers. The sleek design & the wooden cabinets will add an authentic touch to your room interior. Designed with refined wooden cabinets and cool metallic accents, the speaker package creates a full-fledged setting for your home entertainment. Although entry class, the S-RS55TB offers the authentic experience for enjoying music and films.

## JBL Bar 5.1 Powerful 4K UHD Soundbar



**Price:** ₹53,990

It's not an ordinary soundbar. This high-end home theatre lets you enjoy both soundbar as well as a real wireless 5.1 home theatre system for an epic audio listening experience. It comes with two detachable battery-powered wireless surround speakers with 10-hours of playtime.

The 510W home theatre system power with a 10" wireless subwoofer. You can connect 4k devices using the HDMI. It also has Bluetooth connectivity allows the sound switch between Dolby Digital Pro Logic II and DTS, with incredible sound.

## Sony BDV-N9200W Home Theatres System



**Price:** ₹55,190

This home theatre has the audio output is 5.1 surround sound at 1200 W, bringing crisp and clear audio. You can stream high-quality movies and music wirelessly to the Sony home theatre via NFC, Bluetooth, Wi-Fi and Miracast compatibility. The DSEE engine is also capable of upscaling compressed audio formats such as mp3, ACC and WMA to CD quality of audio, all this without losing much of sound quality.

## TOP 6 BUDGET-FRIENDLY HOME THEATRE SYSTEM

### Zebronics SW3490 Multimedia Home Theatre System



**Price:** ₹2,499

One of the most affordable home theatres with 4.1 channel. The speaker supports USB/ SD/MMC card/ AUX. It produces impactful bass with its front-firing woofer. It has a built-in FM and comes with a fully functional remote control. It has a total output power (RMS) 60W.

### Philips MMS8085B/94 2.1 Channel Convertible

**Price:** ₹6,499

As the name suggests, you can use this as a home theatre system as well as a soundbar. It is a 2.1 channel system with two speakers and a subwoofer. The wireless speaker gives you the choice of input, be it aux, FM, CD, audio and Bluetooth.



The home theatre system provides excellent sound quality with a rich bass experience from a loudspeaker box system.

### F&D F3800X 5.1 Channel Speaker



**Price:** ₹6,830

The budget-friendly 5.1 channel music system has five satellite speakers with a subwoofer. Its Bluetooth covers a 15 meters range. It comes with a well-featured remote control and FM connections that work on the latest PLL technology.

The subwoofer contains a 5.25 inches bass driver. This increases sound clarity and you can enjoy the theatre-like sound experience at home.

### Sony DAV-TZ145 Home Theatre System



**Price:** ₹11,992

The 5.1 home theatre system is equipped with 360 Watt RMS that produces high-quality sound and delivers accurate results. The dedicated FM antenna captures signals effectively and offers seamless connectivity. The Dolby Digital feature enhances the overall sound quality, while the Dolby Pro Logic technology generates loud audio in an equally effective manner.

This home theatre system from Sony comes with a digital amplifier which uses advanced amplifying technology that helps in enhancing sound output.

### Sony SA-D40 C E12 4.1 Channel Multimedia Home Theatre System



**Price:** ₹8,490

One of the best Sony home theatre System in the affordable segment. It has four satellite speakers and one subwoofer. The 4.1 channel home theatre system has 80W output and features Bluetooth connectivity along with USB and audio inputs. The bass is fantastic, and it does not distort, so if you are looking for a speaker with a fantastic sound and great bass then this is your choice.

### Philips SPA9080B Multimedia Tower Speakers

**Price:** ₹12,500

Housed in an elegant cabinet, this home speaker has a powerful bass element in the sound.

There is wireless Mic connectivity which means you can sing along with the music and your friends and colleagues can also join in. The karaoke feature allows friends and family to sing together, making for group enjoyment. Connect your phones, tablets, laptops using the Bluetooth. Play your favourite music programs with a powerful and rich sound.



## 6 BEST PORTABLE SPEAKERS

### Harman Kardon Go + Play

**Price:** ₹20,500

Harman Kardon doesn't require any introduction. The Harman Go+ Play Bluetooth speaker has a unique design which stands out from the rest of the speakers available in the market. The build quality to speak about is top-notch. Being a premium luxury Bluetooth speaker, the components used in the construction are of high quality. It comes with a 90mm woofer driver and two 20mm tweeters. Harman has provided a 25W amplifier for each of the speakers to squeeze even the last bit of acoustic richness. Harman Kardon Go+ Play has a giant battery that can last for about eight hours of continuous music playback.



### JBL Flip 5

**Price:** ₹7,899

12 hours of battery life

The JBL's Flip series is known for its build quality and powerful sound output. It has a cylinder design which is covered with a nylon fabric. This cute Bluetooth speaker delivers loud and crisp sound with balanced bass. You won't notice any kind of distortion even at maximum volume levels. But there is a tiny lack of detailing in the sound of certain instruments.



### Amazon Echo Dot

**Price:** ₹3,499

A smart speaker with IoT connectivity. The fourth-generation Echo Dot is the iteration of the same and has various features that will make your life easy and delightful at the same time. The next-gen speaker got a refreshed design and delivers loud, crisp sound with improved bass. Stream millions of songs from Amazon Prime Music, Spotify, JioSaavn, Gaana, Apple Music and Hungama Music. Connect your smart device including lights, ACs, TVs, geysers, and more with the speaker to use your voice to control them. With 4 microphones, Alexa can hear your request from across the room.



### Sony SRS XB12

**Price:** ₹3,499

If you are looking for an affordable yet powerful speaker, then the XB-12 is surely a worthy contender. It has a compact cylindrical design having a metal grill at the top. The body is made of plastic with rubber coating around to give it a textured feel. It has a driver size of 46mm that delivers crisp sound with deep lows and clean mid. There is no noticeable distortion even when played at high volumes. The Sony SRS-XB12 features IP67 certification that will protect the device from water splashes. The wireless speaker lasts up to 16 hours on a single charge before dying out.



### Saregama Carvaan Mini

**Price:** ₹2,490

The Saregama Carvaan Mini is a Bluetooth speaker that comes with 251 retro Hindi songs preloaded. It features a boxy design with rounded edges. The front speaker grill is metallic and the surrounding chassis has a soft rubber finish on top. The speaker has a single 40mm driver with 3W output. It delivers respectable quality sound output for its size with mild bass.

You can pair it up with your smartphone or laptop to stream music wirelessly. There is also a provision for AM/FM radio playback with this device. In one single charge, it can last for up to 4 hours.



### Philips BT40

**Price:** ₹1,298

The wireless Bluetooth speaker has a circular design with the speaker facing upwards. Overall it looks elegant with metallic mesh on top. The Bluetooth speaker has a 40mm driver inside which is loud enough to fill an entire room comfortably. The level of detail in the music is decent with rich bass and complimenting higher notes accompanied with crisp and clean vocals. It is powered by a decent size battery that can go for about 6 hours in one charge.



# CYBER SECURITY JOB ROLES TO WATCH OUT FOR IN 2021

The projected rate of growth for jobs in Cyber Security during 2019–2029 is higher than the average for all other IT professions. The exponential rise in cyberattacks amidst the pandemic has also created an increased demand for the Cyber Security professionals

Sarita Digumarti



**T**he rampant digitization of business operations has increased organisations' vulnerability to cyber threats leading to a huge spike in the number of cyberattacks amidst the pandemic.

Over the last few months, many companies have become victims of cyberattacks, including Twitter, Dr. Reddy's Laboratories, Unacademy, and one of the biggest online grocery platforms in India, BigBasket. Needless to say, companies have now become more

vigilant about organisational security.

The exponential rise in cyberattacks amidst the pandemic has also led to an increased demand for Cyber Security professionals. This is the best time to build a career in this domain, and kickstart your career in it. Having said that, it's also important to pursue a professional course that can help you gain knowledge and hands-on experience to be effective in your role.

Let's take a look at why an aspirant should consider upskilling in cyber security techniques, apart from their interest in the domain.

## Job Security

The demand for Cyber Security professionals is outpacing the talent supply. Despite the global recession, the Cyber Security domain has seen steady growth. Companies are focused on improving their network and information security, and are actively hiring skilled Cyber Security professionals to secure their data. Even before the pandemic, Cybersecurity Ventures had predicted that there would be 3.5 million unfilled Cyber Security positions across industries in the coming years. Now, with remote working becoming a necessity, there's heightened demand for Cyber Security professionals across industries and this number will increase drastically. This means that job security is practically guaranteed for Cyber Security professionals.

## Lucrative Salary

Due to the severe talent crunch and high demand, Cyber Security professionals are among highly compensated professionals. According to IBM, Cyber Security jobs pay 16% more than the average of all IT jobs. The average annual compensation for an entry-level Cyber Security Specialist ranges from INR 5 lakhs to INR 8 lakhs, while a Cyber Security Specialist with 5+ years of experience can earn up to INR 14 lakhs annually.

## Professional Growth

The Cyber Security domain is a brimming ocean of opportunities. As per the Bureau of Labor Statistics, the rate of growth for jobs in Cyber Security is projected at 31% from 2019–2029, which is higher than the average for all other professions. While career opportunities in the Cyber Security domain are many, the knowledge level required to land these jobs is also high.

Now, let's take a look at Cyber Security job roles that one must watch out for in 2021!

**Network Security Engineer:** A Network Security Engineer is responsible for all the security aspects implemented within an organisation. An entry-level Network Security Engineer earns an average annual compensation of INR 4 - INR 5 lakhs.

**Cyber Security Analyst:** A Cyber Security Analyst is responsible for implementing, upgrading and controlling security measures in an organisation, along with testing vulnerabilities, analysing risks, and



**SARITA DIGUMARTI, COO & Co-founder, Jigsaw Academy**

running assessments on the networks to evaluate their stability. An early career Cyber Security Analyst's average income is around INR 5 - INR 6 lakhs annually.

**Security Architect:** A Security Architect is responsible for the network and computer security of an organisation. They act as a project leader to plan, research, and design various elements of organisational security. A mid-career Security Architect earns INR 17- INR 18 lakhs annually.

Apart from the above-mentioned job roles, there are other positions in the Cyber Security domain, like that of a **Cyber Security Manager, Cyber Security Consultant, and Chief Information Security Officer (CISO)**, that will continue to trend in 2021.

Undoubtedly, Cyber Security has emerged as a recession-resilient and booming domain. To land the best jobs in Cyber Security with leading companies, aspirants need to upskill themselves to the latest technologies. When it comes to Cyber Security, pursuing a specialisation program after graduation is always an investment.

The author is COO & Co-founder, Jigsaw Academy



# A GOLDMINE THAT'S WAITING FOR COLUMBUS, NOT FOR MIDAS

We know that enterprises are finding a new land of opportunities on the fresh shores of cloud. But do they know how their maps well?

Pratima H

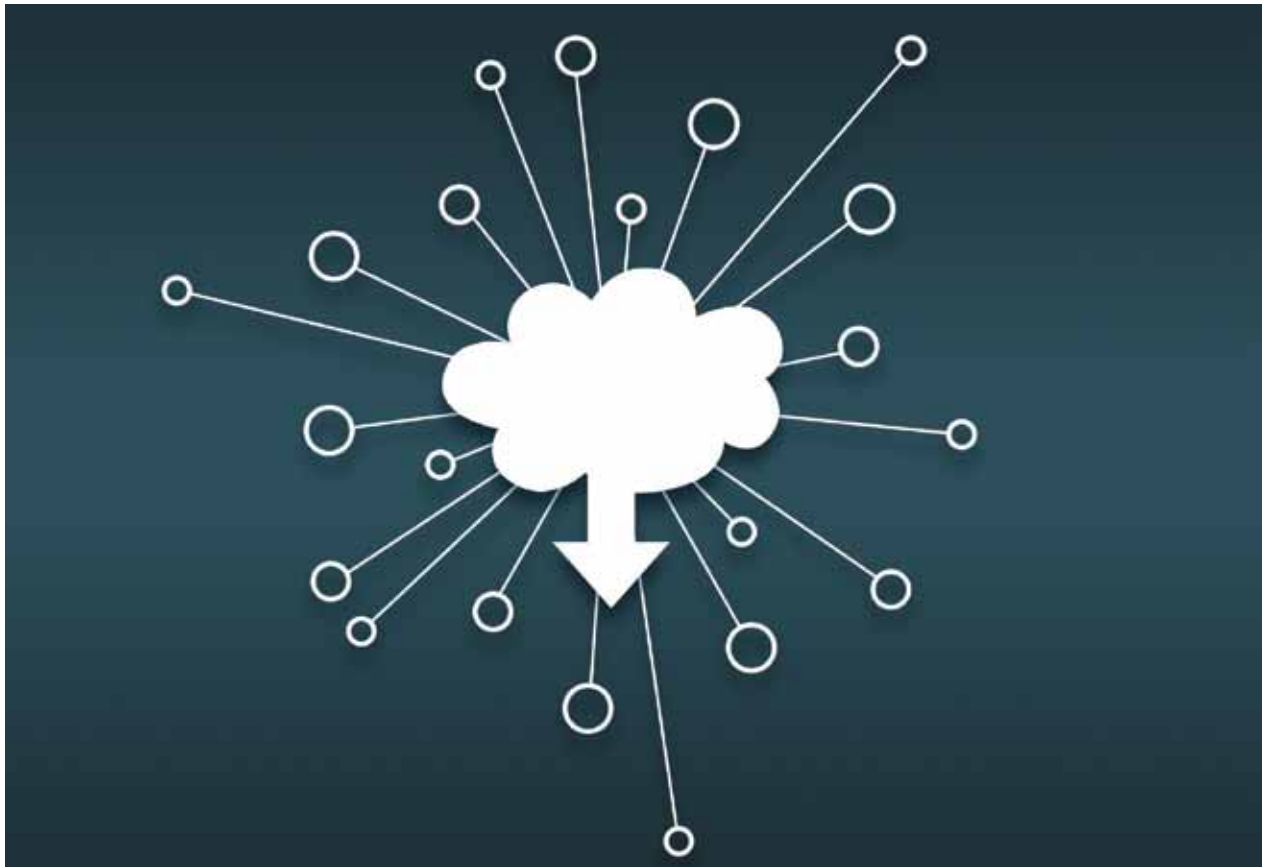

Legacy misfits, interoperability snags, outages, modernisation-hurries, data silos or spiralling cloud costs—a lot can come in the way of making a cloud investment work the way you envisaged it. What goes wrong and where - **Vinod Ganesan, country head – India, Cloudera** tells us all about it.

**How much has the cloud market changed—especially with the advent of shifts toward multi-cloud and hybrid-cloud?**

The business landscape is constantly changing,

and cloud computing is fast becoming native to enterprises today. To keep up with evolving market conditions, businesses are shifting towards hybrid and multi cloud services to remain agile. With digitization in full swing across sectors, fast-tracked by COVID-19, data sits at the heart of making enterprises competitive, aiding innovation and deriving actionable insights to meet customer demands.

With companies working remotely and in distributed teams, there is an urgent need for businesses to scale up their operational platforms and

security measures to remain resilient.

## What are enterprises doing right or wrong as they embrace cloud?

While adopting cloud, companies must assess their requirements as no one cloud model fits all. And to help businesses overcome these challenges and get control of their data, they need to adopt an enterprise data cloud. An enterprise data cloud is a hybrid and multi-cloud platform that uses the full data lifecycle to help organisations extract the true value from their data.

## What are the new trends and challenges that you see emerging in the enterprise market?

Businesses today are sitting on a gold mine of data, but they have yet to fully leverage it to make insight-driven decisions. As more companies deploy cloud, getting the data right will become crucial to their success. IT teams are finding that their legacy systems and data platforms can't keep up with current requirements and needs of their business.

## Can you elaborate on this?

A survey published by IDC in May 2020 revealed that due to the global outbreak, 64 per cent of the organizations in India are expected to increase demand for cloud computing while 56 per cent for cloud software to support the new normal. The survey also highlighted that VPNs, collaboration suites, end-point encryption, and cloud tools will witness an uptick in adoption by Indian enterprises. Another change that the Indian IT industry has seen this year is the decline in data center infrastructure spending. Gartner reported that spending on data center systems in India has seen a steep decline of 13.2 per cent in 2020. As enterprises increase spending on technologies such as Desktop as a Service (DaaS), Infrastructure as a Service (IaaS) and security, we will see a corresponding increase in cloud adoption by organizations to modernize their IT infrastructures.

## So the 'how' is a missing piece, even now?

The way to address that deployment in an efficient manner is to drive the cloud strategy from the enterprise data strategy, thereby empowering every team with the data and resources required to develop the best intelligence for the business. Although organizations understand the need to be data-driven, many are struggling to achieve it, especially if they are adopting hybrid or multi cloud



**VINOD GANESAN, Country Manager, Cloudera**

to also gain business agility. Our research survey with Harvard Business Review revealed that 69 per cent of executives globally recognize the need for a comprehensive data strategy to meet their business goals but only 35 per cent think their current strategy is sufficient. Two commonly cited barriers to maximizing data for strategic gain are: data silos or having multiple data copies (54 per cent), and the lack of interoperability between systems (44 per cent). These factors hinder data accessibility and the organization's ability to ingest data fast enough to make decisions in real-time, as well as make it challenging to comply with increased data privacy regulations soon.

## Any thoughts on how much has been solved on areas like—outages, over/under-provisioning, interoperability, cloud migration and security?

Data is the fuel that powers enterprise digital transformation, but often, companies struggle to manage the disparate data across multi-cloud and

hybrid environments. Overwhelmed by data pouring in from different sources, they face a challenge to combat proliferating data silos or spiralling cloud costs. We've helped many customers, some of whom are leaders within their own verticals, in the region gain enterprise-wide intelligence to serve their customers better, operate with greater efficiency, and strengthen security to protect their business. At Cloudera, we focused on providing our customers with some key capabilities. With these capabilities, customers can rapidly onboard mission-critical applications that can be run from anywhere without any disruption to existing ones, and also respond to changing market conditions in an agile manner without compromising on security or data governance.

### **What is the role that DataOps can play in making cloud investments profitable and frictionless for enterprises?**

As the demand for access to data assets and data products across multiple environments increases, IT teams are looking for ways to streamline the development and delivery of data to better support business operations. DataOps is an emerging concept that has gained momentum in the IT community recently. In short, the goal of DataOps is to improve the efficiency of data analysis by introducing automation and new processes purpose-built for faster turn-around. We recently launched new enterprise data cloud services on CDP—it enables full data lifecycle management, from data streaming to machine learning and AI, enabling best-in-class enterprise data management on any cloud or data center.

### **Are cloud players and their offerings making cloud more complex than simple?**

Supercharged with the ongoing pandemic, every business today—from retail to healthcare—has gone digital almost overnight, resulting in more data being generated than ever. Faced with so much data, companies have to now think about the way they ingest data, the way they clean up the data and ultimately how to leverage that data to get clear and actionable insights.

Cloudera believes this onslaught offers an opportunity to make better business decisions, faster. Ex-CDP also allows IT departments to manage and secure the entirety of the data lifecycle in any cloud or in any data centre, making data easier than ever to collect, process and analyse.

### **What changes have hyper-scale players brought to the cloud space?**

The cloud market is becoming increasingly saturated and that has resulted in anxiety among organizations who try to execute a cloud strategy as quickly as possible. Offerings from the hyperscale cloud provider offerings are centered around data-intensive software framework and they are mostly verbatim subsets of the many open source initiatives that we deliver on CDP. The involvement of the cloud providers is mostly unidirectional and consumes open-source assets with little contribution to it.

This is where we come in. Cloudera has the ability to drive critical fixes and influence the strategy of open-source frameworks. Identifying the needs of cloud-native innovations, we deeply invest in developer communities, to add value for them by quickly moving large scale data around the software ecosystem and data centers, on- or off-premise, in the most efficient way possible.

### **What advice would you give to CIOs to address problems around cloud tools, re-architecture, third-party players, workload-selection etc.?**

While transitioning to the cloud, enterprises must not lose sight of their data—a strategic asset that calls for an enterprise data strategy. CIOs need to understand that without an Enterprise Data Strategy, a cloud strategy alone would hamper managing, accessing, securing, governing, and deriving insight from data. The enterprise data strategy informs the modern data architecture that makes up the enterprise data cloud.

Especially with remote working, companies are utilising cloud services and storage capabilities to facilitate WFH and distributed teams management. Due to which, data is being stored in various locations, rendering their confidential data to be exposed to vulnerabilities. Governance of data spread across IT environments also becomes a challenge for organizations. For organisations to thrive in the new normal, insight-driven decisions by tapping into old and new data sources will help companies gain a competitive advantage. Realizing this, half of the companies HBR surveyed plan to use more advanced analytics, such as machine learning and artificial intelligence (AI), by 2023 to fully extract the business value embedded in data. It is, therefore, imperative to have an effective data strategy in place that supports multiple analytics frameworks—from real-time analytics at the Edge to AI.



# TAKE YOUR SHARED SERVICE CENTRE TO THE NEXT LEVEL WITH AUTOMATION

Staying on the cutting-edge, now and in the future, requires SSCs to “accelerate digital” and automation is an important step towards digitization

Virender Jeet



**W**ith increasing competition and improvement in technology shared services centres (SSCs) are no longer centered towards cost optimisation only.

Modern SSCs are rapidly transforming into significant value generators, delivering agility and flexibility across a multitude of complex processes.

However, ever-growing service portfolios,

continuously evolving regulations, and heightening customer expectations, are driving SSCs to adapt even further. It has become urgent for them to embrace and effectively leverage new-age technologies, such as mobility, analytics, cloud, and intelligent process automation, to differentiate their services and stay future-ready.

### Three Key Arguments for Expediting Automation in Shared Services

At a time when digitisation is the expectation and technology is near-inescapable, the question surrounding automation is no longer “if,” but rather, “how quickly?” and “to what end?”

For SSCs looking to seamlessly digitise their operations, perhaps the most crucial step is to clearly define their goals and understand the benefits of automation. The three main arguments for automating shared services are:

**Process optimisation** – Implement automation, virtualization, advanced analytics, and other new-age technologies to streamline your end-to-end processes. Bring greater speed and accuracy to common back-office functions, such as finance and accounting, human resources, and IT. Empower your employees to make more informed decisions, improve the quality of internal and external customer interactions, and optimise your time, resources, and costs.

**Intelligent operations and insights** – Automate your operations and enable your SSC to intelligently execute more complex functions, such as sales and research and development, on top of the typical, contextual processes, including finance and HR.

Furthermore, generate even greater value by analysing the data captured within your SSC. Use analytics capabilities, among other technologies, to interpret the data, create insights, and optimise your outcomes. Use data-based benchmarks to compare business units, illustrate best practices, innovate new product/service ideas, and more.

**Scalable services** – Expand the geographical coverage of your SSC by reducing operating costs and bridging organisational silos through digitisation. Also, increase the functional scope of your SSC to offer a more complete and scalable service portfolio.

Proactively respond to the changing needs of your internal and external customers, while mitigating your organization’s dependence on external service providers. Improve your in-house control, transparency, process standardisation, and



**VIRENDER JEET, SVP (Sales & Marketing, Products) Newgen Software**

agility by consolidating your technology investments, operations, and analytics.

Alternatively, skip the investment of automating your enterprise and instead source your shared services to an external business process services (BPS) provider. Free up your employees to focus on core business initiatives, while the BPS provider leverages their experience and advanced technologies.

### Boost the Bottom Line

“Consolidation, standardization, and scale,”— according to Deloitte, these have been the defining principles of shared services since the beginning. When we look at modern SSCs, the basic goals have not changed. However, the way in which those goals are achieved have evolved.

SSCs now have the means and the opportunity to use technology and automation tools to intelligently optimise their processes, deliver superior experiences to their internal and external customers, maintain compliance, and significantly boost their bottom line.

The author is SVP (Sales & Marketing, Products)  
Newgen Software

# COVID-19: THE TRIGGER FOR CREATING A HYBRID WORKFORCE

Changing the axis of automation from process to humans can help organizations create better work environments for people

Sandeep Kumar



**C**COVID-19 has shown us that automation is inseparable from a well-thought-out strategy for digital transformation. Popular narrative suggests that automation provides the backbone to create resilient organizations, ones that can withstand and recover from history-making COVID-19-type disruptions. This is undeniably true, and which is why with lockdowns and social distancing squeezing the availability of talent, the demand for automation has been rising.

There is quantifiable evidence to back this: between early January and mid-April this year buyer intent for Robotic Process Automation (RPA) surged by 162 percent. Clearly, the urgency to insert bots in place of humans has been driving the trend. Much of the demand has been driven not just by the resilience factor, but by the ability of automation to lower costs. Smarter organizations had a different reason: their digital strategy said that automation serves a better purpose when it supplements and complements employees, amplifying human potential. These smart organizations are busy providing their employees with digital assistants (aka digital buddies or bot buddies). They are creating a new type of powerful and

futuristic hybrid workforce.

Organizations investing in automation to enhance human potential are going a step beyond resilience. They are building antifragile organizations—a term coined by Professor Nassim Nicholas Taleb in his book “Antifragile: Things that Gain from Disorder”. The difference between resilience and anti-fragile is significant and demands examination in the light of COVID-19 and its impact on business. Resilient organizations quickly bounce back to their pre-shock condition; antifragile organizations, on the other hand, thrive, grow and move on as a result of stress and shock.

## Creating an Hybrid Workforce

There are several approaches to creating a hybrid workforce that is productive and results in employee engagement. For many businesses, especially those in India, perhaps the most effective is to move away from using automation to save man-hours. This is because the existing low cost of talent makes “saving man-hours” a poor use case for automation. Changing the axis of automation from process to humans can lead to a breakthrough. The human focus will liberate

employees from mundane activities. The repetitive tasks they manage can be executed by their digital co-workers. This will give them the time to use their intuition, imagination, experience and cognition (critical aspects that machines cannot replicate) to perform their roles better.

Think of applying automation (RPA) at two levels to augment human potential and create a hybrid workforce:

1. Identify organizational job roles or personas that can be automated, then create a catalogue of bots or digital assistants to serve job families within the organization. These could include Quality Management Personas, Project Management Personas and Testing Personas. The digital assistants then collaborate with employees to deliver results faster, better and –sometimes – cheaper!

2. Identify tasks that all employees perform such as applying for leave and reimbursement claims. Now, a Digital Buddy (that everyone can use) can be devised to perform these tasks. You can think of this as the democratization of automation since every employee has access to the technology to make life simpler.

### Benefits of Hybrid Workforce

It is gratifying to observe the outcome of a strategy that amplifies human potential. By making automation available across the organization, the environment can become rich in technology nutrition. Employees, who were previously (understandably) wary of automation, can embrace it and become comfortable presenting ideas and proposals rooted in automation for projects and to potential clients. They will also do this with greater conviction. But perhaps the biggest upside can be the rightsizing of job roles. This is best explained with an example. Take the role of a Project Planner. The job description of a Project Planner is all about analytics and decision support. In reality, a Project Planner spends 70% of the time in data aggregation and reporting. Decision support is a minor part of the job. However, a digital assistant using automation can help with a considerable amount of the aggregation and reporting tasks, providing the Project Planner with more time to invest in actual decision support.

A simple exercise like mapping the life of a tester and identifying a dozen or more use cases that account for 20% of a tester's time can potentially deliver upwards of 25% in productivity gains through automation. In a typical technology environment, digital assistants can be developed for roles in PLM



**SANDEEP KUMAR, Sr. VP & Head Global Consulting, ITC Infotech**

and application development, fulfilling the vision of a hybrid workforce.

COVID-19 will force organizations to think harder about what they can do with automation/RPA. Of course, automation can take away costs and build resilience. But more importantly, it can manage spikes in demand without adding headcount or manage a dip without having to think about laying off employees.

Organizations will increase their investments in automation as they see the impact it can make beyond costs. Analysts agree that investments in automation will grow exponentially starting now until 2025.

Organizations that invest larger proportions of their automation budgets on developing a hybrid workforce will create better work environments, attract superior talent and even find greater investor interest. It is a near guarantee that the effects of automation as the basis for a hybrid workforce will have longer-lasting outcomes than using it to automate narrow processes.

The author is Sr. VP & Head Global Consulting, ITC Infotech

# PRODUCT REVIEWS

## A Powerful Marketing Vehicle

Thousands & thousands of products are launched every year. But a bunch of them are reviewed. A good product backed by experts' review translate into increased user interest and hence sales. Get your product reviewed by CyberMedia Labs which is run by a team of experts/product technologists having 10+ years of experience.

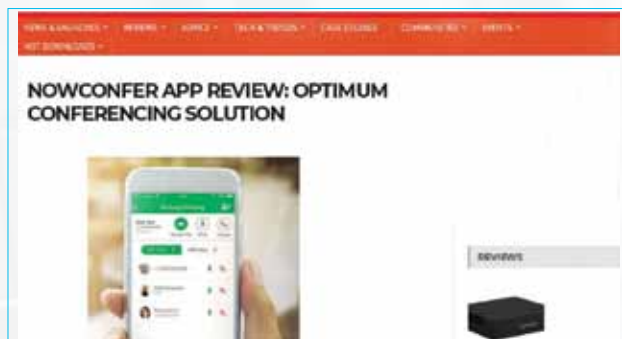
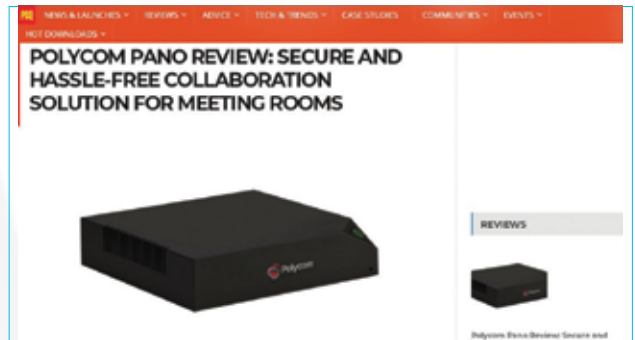

Visit [www.cybermedia.co.in](http://www.cybermedia.co.in) for more product reviews by CyberMedia Labs

### SOME OF THE CATEGORIES CYBERMEDIA LABS SPECIALIZES IN:

• Firewalls	• UTMs	• Thin Clients
• IT Infrastructure Hardware & Software	• Networking Devices	• Printers & MFDs
• Audio Equipment	• Cameras	• Smartphones & Tablets
• TVs & Display	• Computers & Laptops	• Tools
• Games	• Mobile Apps	• Imaging



**To leverage the opportunity of product reviews by CyberMedia Labs**

**Contact us:**  
Rajiv Pathak  
Marketing

marketing@cybermedia.co.in,  
+91 8010757100, 0124 482 2222, ext: 219



NAS

# SYNOLOGY DISKSTATION DS920 +

— Ashok Pandey  
ashokpa@cybermedia.co.in

Whether PC/Laptop or smartphone, every user is struggling with storage space. Though these devices come with plenty of storage space, but not enough. The operating system captures a good amount of space and then you need a decent space to manage future OS updates. After these, you rely on external drive to store your data.

To cater the storage challenges of power users and small-to-mid-sized (SMB) users, Synology introduced DiskStation DS920+. This is four-bay network-attached storage (NAS) device that is easy to expand. The NAS supports various third-party apps, including Synology's powerful Collaboration Suite, for the ease of use.

## Design and Features

The overall built and design is nearly identical to its previous siblings. The front has four front-loading, tool-free drive bays, a USB 3.0 port, a backlit power switch, and five LED indicators for system status and drive activity (one for each drive). At the back, it has two LAN ports, a secondary USB 3.0 port, and an eSATA port.

The Synology DS920+ is equipped with a quad-core 2 GHz Intel Celeron J4125 processor along with 4 GB of DDR4 RAM that can be expanded to 8 GB. The NAS can house four drives of 2.5-inch or 3.5-inch SATA or SSD drives. A total of 64 TB of internal storage can be created with DS920+.

To configure the DS920+, you need to download Synology's DiskStation Manager (DSM) app. A simple to use operating system that lets you configure drives, monitor NAS health, create shared folders, handle security and download apps.

When you run the DSM for the first time, it appears with icons labelled Control Panel, File Station, Package Center, and Help. You can check the system health CPU and RAM usage using the DSM. You can also download more apps depending upon your requirements. Using the Control Panel, you can create users and assign their rights. Control panel also lets you create shared folders, configure network settings, and block IP addresses.

## Easy to setup

Synology DS920+ is quite easy to set up, first install four drives, we added four Seagate Iron Wolf 2 TB drives in each sled. The NAS comes with a LAN and power cable. once drives are installed, connect the NAS the router using LAN cable, then power up the device. Now open a browser on your PC which is connected to the same router, type <http://find.synology.com> in the address bar.



Price: Starts at ₹54,358 on Amazon

## SCORE

Overall: **9/10**

PRICE: **8/10**

PERFORMANCE: **9/10**

FEATURES: **9/10**

**KEY SPECS:** Quad-core 2 GHz Intel Celeron J4125 processor, 4 GB DDR4 RAM, Maximum 9 Drive Bays with Expansion Unit DX517, 2 M.2 Drive Slots

**PROS:** Built quality, transfer speed, numerous apps, dual LAN ports

**CONS:** Slightly expensive

A utility will immediately look for the device and will install the latest version of DSM. Now you can setup Admin account and set up the drive configurations.

## Performance

We connected the NAS to our network router and then after setting up things, we started testing the performance of the DS920+. After finalising the configuration, we gave access to multiple users to test its ability. We used it in a real-world scenario, stored various data on the shared drive, access restrictions to particular users and other settings. It was outstanding in deploying and allocation specific right to the users.

To test file transfer performance, we transferred 5 GB folder with assorted data, containing videos, photos, music files and document files between the NAS and a host PC. It delivered excellent transfer speed of 98.6 MBPS when PC to NAS and 104.8 MBPS when NAS to PC. However, speed can differ depending on your connectivity through the router and the connected drive in the BOX.

**Bottomline:** The Synology DiskStation DS920+ is quite easy to set up the device and it has a fairly good transfer speed. The 4-bay NAS offers a great selection of optional server, backup, and productivity apps. It is a perfect solution for power users and SMBs.

## MONITOR

# VIEWSONIC VX3258-2KC-MHD MONITOR

— Ashok Pandey  
ashokpa@cybermedia.co.in

**V**iewSonic VX3258-2KC-MHD is a 32-inch curved monitor with WQHD 2560 x 1440 resolution and dual stereo speakers. A good screen always enhances your computing and gaming experience. Whether you are upgrading or buying a new monitor, you must be looking for a perfect option.

The latest offering from ViewSonic is a decent quality gaming monitor aimed at gamers. Let's find out whether would it a right monitor for gamers.

## Design and Features

The curved ViewSonic monitor looks pretty good. It has very thin bezels, with a minimalist stand that fits to its design. You can tilt the monitor to find the best angle. But unfortunately, you can't change the height.

The monitor has 2 DisplayPorts, 2 HDMI 2.0 inputs and a 3.5mm audio-out jack. All the ports are at the back. You can easily access those ports and connect power to the monitor to begin your new gaming journey.

The gaming display supports 1ms MPRT response time, perfect for the most graphic-intensive gaming. With a swift 144Hz refresh rate, the screen has Flicker-Free technology and a Blue Light Filter help eliminate eye strain caused by harmful light rays and periods of extended viewing.

ViewSonic's exclusive ViewMode offers specialised presets to fit different usage scenarios including Game, Movie, Web, Text, Mac, and Mono modes. These presets enhance gamma curve, colour temperature, contrast, and brightness to deliver the optimal viewing characteristics for each application. Additionally, it has AMD FreeSync technology that eliminates screen tearing and choppy frame rates.

The monitor is equipped with a couple of speakers, but they're not that loud to be used for gaming. They can be used for light music.

## Performance

Setting up the monitor took a few minutes only. There is no complicated configurations to make. Connect the monitor your PC and if you want some customization, you can do that easily. For normal PC usage, the display is perfectly fine with vibrant colours and the curved screen definitely helps with immersion and viewing angles. Its resolution and image quality made it a pleasure to use day in day out.

To test its gaming ability, we played different games including Assassin's Creed Valhalla, Ghostrunner, Call of Duty Modern Warfare, etc. The screen was able to deliver an enjoyable experience. Colours were looking pretty good, but not overly vivid.

Having the curved panel, the experience



Price: ₹49,000

## SCORE

Overall: **8/10**

PRICE: **8/10**

PERFORMANCE: **8/10**

FEATURES: **9/10**

**KEY SPECS:** 32-Inch screen; WQHD 1440p resolution; 144Hz refresh rate; AMD FreeSync technology; 85% NTSC wide colour gamut coverage; Dual HDMI and dual DisplayPort inputs

**PROS:** Easy to set up, stylish design, multiple settings and options, decent resolution

**CONS:** Lacks at sharp images and dark shades

with the motor was immersive. The screen was looking good but most of the times, we were noticing the refresh rate. Having pretty good resolution, the picture being smooth even in the most frantic of exchanges, but not as crisp and detailed as higher-end panels. It was able to do great with bright colours, but the dark shades and black colours were not the deepest.

Overall, it is a decent monitor but a little lacking. It offers a decent balance of speed and picture quality, though doesn't truly excel at either.

**Bottomline:** This curved screen offers decent image quality. You can enjoy playing different games on it however with some high-end games, it wasn't up to the mark. If your budget is tight, then ViewSonic VX3258 could be a tempting choice, but at the lesser price.



**LEADING TECH MEDIA PLATFORM & NETWORK SINCE 1982**



**6** Brands

**3500+** Impact Articles

**20+** Webinars & Virtual Roundtables

**9000+** Attendees Across Verticals

**90,000+** People Influenced

**90+** Industry Leaders & Tech Experts



### COMMUNITIES

Technology Decision Makers - Enterprise and SMB, Telecom, Channel Partners, Start-ups, DeepTech, Functional Heads and many more

## MOVED THE NEEDLE DURING COVID-19 CRISIS

- From Survival to Revival
- Proactive Business Recovery
  - Changing Customer Expectation in Crisis
- Cyber-Sanitize your business
- Proactive Sales Strategies for faster business recovery
  - New IT Priorities 2020



- CXO of the Week
- CiOL Live Video Series
  - Start-Up Circle
  - CiOL Cloud Burst
- CiOL Live Tech News



- Are There any Make in India IT Products for Us to Use?
- Cloud Adoption in Digital World
- Govt to Harness IT to Empower MSME Sector



### CREATING HIGH IMPACT & INFLUENTIAL CONTENT IN THE LAST 200 DAYS



- **DQ TECH** Series
- Business Continuity Planning Series
- Dataquest Digital Indexing
- DeepTech (India's largest Virtual Conference)



- Secure Smart & Intelligent Network
- App Modernisation
- Collaboration in WFH environment
- DevOps
- **CyberMedia** Product Review



- Business After Covid
- TLF Dialogue Series
- 25 Years of Mobile Telephony India

and many more....

# Dell EMC VxRail™ now powered by AMD EPYC™ processors

Built for VMware®, with VMware, to enhance  
VMware, VxRail is the easiest way to deploy  
vSAN.

AMD  
**EPYC**

**DELL**Technologies

