

- (vi) Which among the statements given below is/are the property of 'Complete Incidence Matrix'?
  - (a) Determinant of a loop of a complete incidence matrix is always zero
  - (b) Addition of all entries in any column should be equal to zero
  - (c) Rank of connected or oriented graph is always 'n-1'
  - (d) All of the above.
- (vii) When compared to a first order low pass filter, a second order low pass filter has
  - (a) lower voltage gain
  - (b) higher voltage gain
  - (c) faster drop in filter response
  - (d) higher cut off frequency.
- (viii) Which among the following represents the precise condition of reciprocity of ABCD parameters?
  - (a)  $AB - BD = 1$
  - (b)  $AC - BD = 1$
  - (c)  $BC - AD = 1$
  - (d)  $AD - BC = 1$ .
- (ix) Given  $V_{th} = 20V$  &  $R_{th} = 5\Omega$ , the current in the load resistance of the network is
  - (a) 4A
  - (b) infinite
  - (c) more than 4A
  - (d) 4A or less.
- (x) Transient current in an RLC circuit is oscillatory when
  - (a)  $R = 2\sqrt{\frac{L}{C}}$
  - (b)  $R < 2\sqrt{\frac{L}{C}}$
  - (c)  $R > 2\sqrt{\frac{L}{C}}$
  - (d)  $R = 0$ .

**Group - B**

- 2. (a) Find out the current flowing through  $(-j6)\Omega$  using mesh analysis by matrix method.

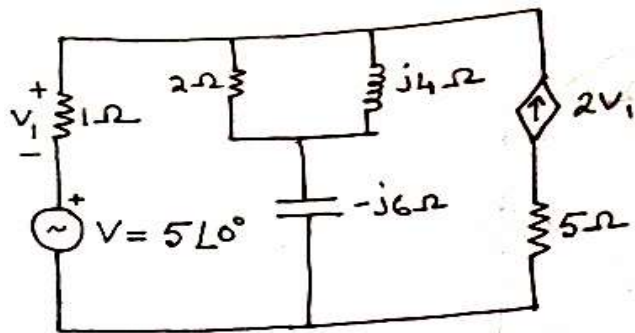

**Group - D**

- 6. (a) Form complete incidence matrix from the directed graph given in the following figure.

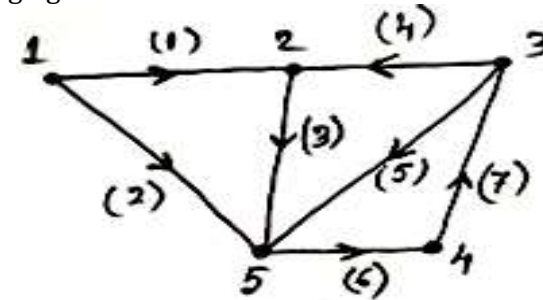

- (b) Consider the tree, of the above graph, given in the following figure and form tie-set matrix and cut-set matrix.

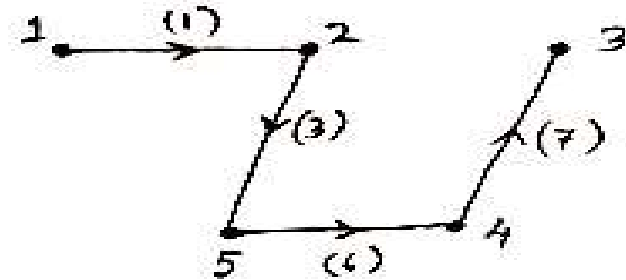

$4 + (4 + 4) = 12$

- 7. (a) Write a spice program to plot the transient current  $i(t)$  of the given figure where  $v(t) = 10V$

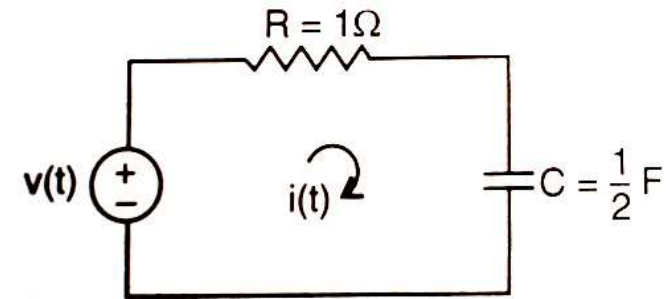

- (b) Explain the function of any two of the following:
  - (i).PRINT
  - (ii).PLOT
  - (iii).AC.

$6 + 6 = 12$

**Group - E**

8. (a) Define ABCD-parameters.  
 (b) Obtain z- parameters for the following circuit.

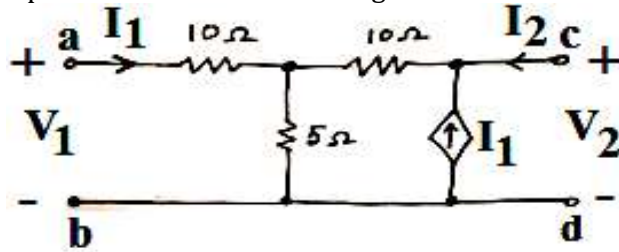

- (c) Determine the condition of reciprocity for Z-parameter. 2 + 6 + 4 = 12

9. (a) Analyze the circuit and find out the cut off frequency. Hence comment which type of filter is shown in figure.

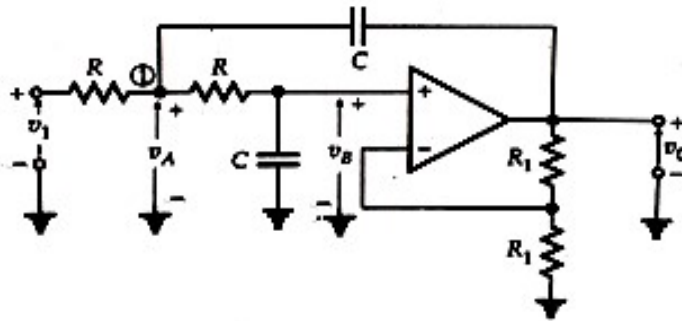

- (b) Explain under what condition a RC circuit behaves as a Low pass filter. 6 + 1 + 1 + 4 = 12

**CIRCUIT THEORY  
 (ELEC 3001)**

Time Allotted : 3 hrs

Full Marks : 70

*Figures out of the right margin indicate full marks.*

*Candidates are required to answer Group A and any 5 (five) from Group B to E, taking at least one from each group. Candidates are required to give answer in their own words as far as practicable.*

**Group - A  
 (Multiple Choice Type Questions)**

1. Choose the correct alternative for the following: 10 × 1 = 10
- (i) A circuit has resistors, capacitors and semi-conductor diodes. The circuit will be known as  
 (a) non-linear circuit (b) linear circuit  
 (c) bilateral circuit (d) both linear & bilateral.
- (ii) Application of Norton's theorem to a circuit yields  
 (a) equivalent current source and impedance in series  
 (b) equivalent current source and impedance in parallel  
 (c) equivalent voltage source and impedance in series  
 (d) equivalent voltage source and impedance in parallel.
- (iii) What would be the nature of 'Z<sub>L</sub>', if 'Z<sub>eq</sub>' reactance is inductive according to 'Maximum power transfer theorem'?  
 (a) Inductive (b) Capacitive  
 (c) Resistive (d) All of the above.
- (iv) What is the initial value of the given transfer function  $\frac{1}{s(s+2)}$   
 (a) 0 (b) 2 (c) infinite (d) 1.
- (v) Laplace Transform analysis gives  
 (a) time domain response only  
 (b) frequency domain response only  
 (c) both (a) and (b)  
 (d) neither (a) nor (b).

- (b) In the circuit if  $R_1 = R_2 = 4\Omega$ , find the short circuit current through x-y terminal.

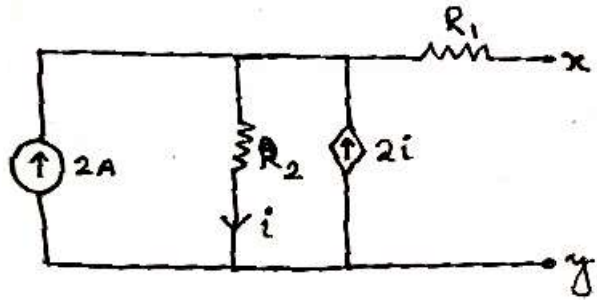

7 + 5 = 12

3. (a) Obtain the Thevenin's equivalent parameters of the circuit shown at terminals A-B.

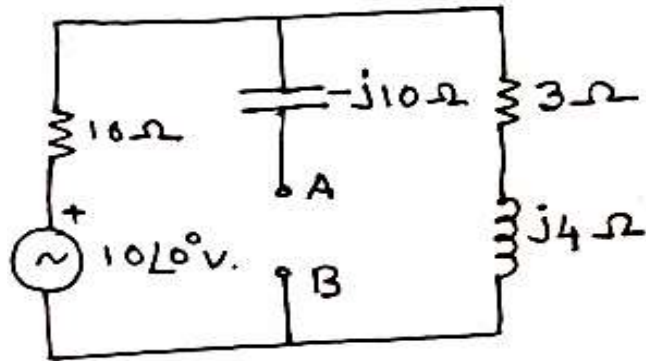

- (b) Find the power loss in 5Ω resistor using Superposition Theorem.

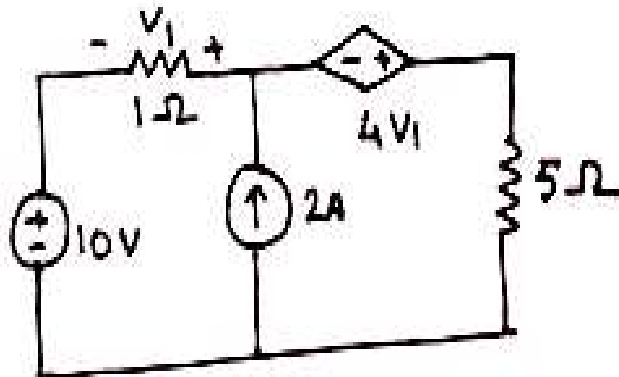

6 + 6 = 12

**Group - C**

4. (a) Define 'Gate' signal and delayed ramp signal where delay time is T.  
 (b) Find Laplace Transform of given signal shown in figure.

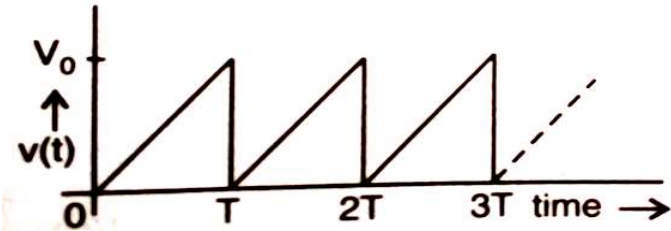

- (c) Define an impulse function and show that it is the first derivative of a 'Step function'.

3 + 6 + 3 = 12

5. (a) In the following circuit input voltage is given. Obtain Transient current  $i(t)$  through the circuit. Define time constant of a R-C circuit.

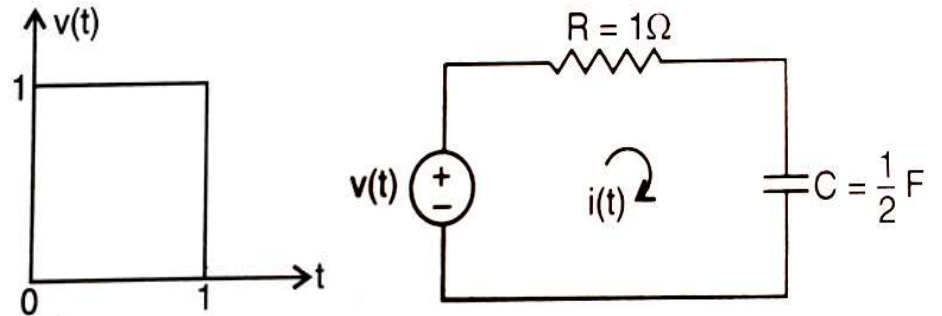

- (b) In the circuit switch S is closed and steady state condition is reached. Now at  $t = 0$  switch S is opened. Obtain the expression for the current through the inductor.

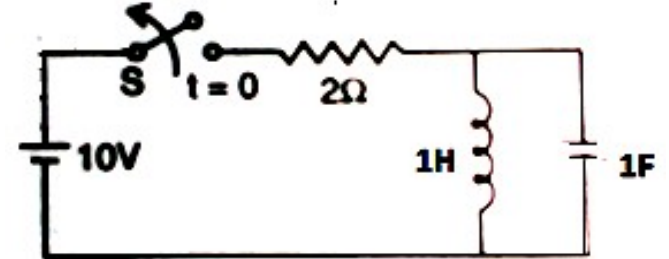

(6 + 1) + 5 = 12