



- (viii) What is the primary difference between a Finite Automaton (FA) and a Pushdown Automaton (PDA)?  
 (a) An FA has a stack, while a PDA does not.  
 (b) A PDA uses a stack, while an FA does not.  
 (c) An FA can only read input, while a PDA can also modify the stack.  
 (d) Both b and c.
- (ix) The following move of a PDA is on the basis of:  
 (a) Present state (b) Input Symbol  
 (c) Present state and Input Symbol (d) None of the mentioned
- (x)  $S \rightarrow aABC \mid a$   
 $A \rightarrow aA \mid B$   
 $B \rightarrow aBA \mid C$   
 $C \rightarrow \epsilon \mid aC$   
 The null-able variables for the above grammar are  
 (a) S, A, B, C (b) S, A, C (c) A, B (d) A, B, C

*Fill in the blanks with the correct word*

- (xi) A finite state machine M has a finite output memory iff it's corresponding testing graph G is \_\_\_\_\_.
- (xii) Finite Automata recognize \_\_\_\_\_.
- (xiii) Push down automata accepts \_\_\_\_\_ languages.
- (xiv) Merger graph is used to determine the set of all \_\_\_\_\_.
- (xv) A CFG is said to be Greibach Normal Form(GNF) if all production have the form \_\_\_\_\_.

### Group - B

2. (a) When two states of a machine are distinguishable. [[CO1] (Apply/IOCQ)]  
 (b) Consider the following machine:

PS	NS,Z			
	I1	I2	I3	I4
A	___	___	E,1	___
B	C,0	A,1	B,0	___
C	C,0	D,1	___	A,0
D	___	E,1	B,___	___
E	B,0	___	C,___	B,0

- (i) Draw the merger graph.  
 (ii) Draw the compatibility graph.  
 (iii) Find the minimal closed covering with justification. [[CO1](Evaluate/HOCQ)]

**2 + (5 + 3 + 2) = 12**

3. (a) In response to an unknown input sequence, the machine of the following table produces the output sequence 1110000010, Find the input sequence to the machine if it is known that its initial state is A and its final state is F.

PS	NS,z	
	x=0	x=1
A	B,1	C,0
B	D,1	B,1
C	E,1	B,0
D	A,0	E,0
E	F,0	D,1
F	D,0	A,1

[[CO1](Evaluate/HOCQ)]

(b) Design a merger table of the following machine:

PS	NS, Z	
	I1	I2
A	E, 0	B,0
B	F, 0	A,0
C	E, _	C,0
D	F, 1	D,0
E	C, 1	C,0
F	D, _	B,0

[[CO1](Evaluate/HOCQ)]

**(4 + 3) + 5 = 12**

### Group - C

4. (a) Prove that  $L = \{ 0^n 1^m \mid n \leq m \}$  is not regular. [[CO3] (Analyse/HOCQ)]  
 (b) Construct a regular expression corresponding to the state diagram of the following figure

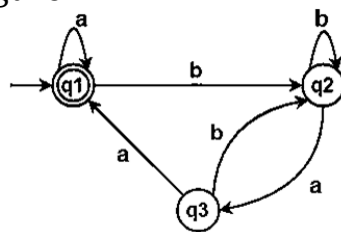

[[CO3](Evaluate/HOCQ)]

- (c) Compare between Mealy machine and Moore machine.

[[CO1](Apply/IOCQ)]

**4 + 5 + 3 = 12**

5. (a) Using Ardens' theorem find out the regular expression for the following FA:

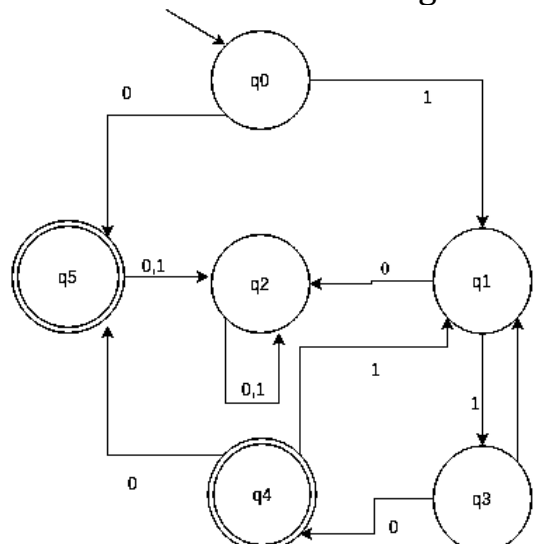

[[CO3] (Apply/IOCQ)]

- (b) Define Mealy machine and compare it with Moore machine. [[CO1](Understand/LOCQ)]  
**8 + 4 = 12**

### Group - D

6. (a) Let G be the grammar  
 $S \rightarrow bB|aA$ ,  $A \rightarrow b|bS|aAA$ ,  $B \rightarrow a|aS|bBB$   
 For the string bbaababa find  
 (i) Leftmost derivation (ii) Rightmost derivation (iii) Parse tree.  
 Where S is the Start symbol. [[CO4](Understand/LOCQ)]
- (b) Convert the following productions into Chomsky's Normal Form(CNF):-  
 $B \rightarrow aBB|C|abA$   
 $C \rightarrow aCC|aa|D|a$   
 $D \rightarrow \epsilon | dd$  [[CO5](Apply/IOCQ)]  
**(3 × 2) + 6 = 12**
7. (a) Construct a DFA corresponding to the following regular grammar  
 $S \rightarrow 0S | 1A$   
 $A \rightarrow 0B | 0C$   
 $B \rightarrow 1A | 1C | 0$   
 $C \rightarrow 1S | 1$  [[CO4](Apply/IOCQ)]
- (b) Convert the following productions into Greibach Normal Form (GNF):-  
 $S \rightarrow AB$   
 $A \rightarrow aA | bB | BA$   
 $B \rightarrow b$  [[CO5](Apply/IOCQ)]  
**7 + 5 = 12**

### Group - E

8. (a) Construct a PDA for the languages  
 (i)  $L = \{ w \in \{a,b\}^* \mid w \text{ has the equal number of a's and b's} \}$ .  
 (ii)  $L = \{ 0^n 1^m \mid n > m \geq 0 \}$ . [[CO6](Apply/IOCQ)]
- (b) Explain Instantaneous Description (ID) in PDA with an example. [[CO6](Understand/LOCQ)]  
**(2 × 4) + 4 = 12**
9. (a) Design a Turing machine for the regular expression  $0^*11^*$ . [[CO6](Analyse/HOCQ)]
- (b) Compare between Multitape Turing machine and Non Deterministic Turing machine. [[CO6](Apply/IOCQ)]  
**8 + 4 = 12**

---

Cognition Level	LOCQ	IOCQ	HOCQ
Percentage distribution	17	43	40