

**FUNDAMENTALS OF DATA STRUCTURE AND ALGORITHMS  
(INF2101)**

**Time Allotted : 2½ hrs**

**Full Marks : 60**

*Figures out of the right margin indicate full marks.*

*Candidates are required to answer Group A and  
any 4 (four) from Group B to E, taking one from each group.*

*Candidates are required to give answer in their own words as far as practicable.*

**Group – A**

1. Answer any twelve: **12 × 1 = 12**

*Choose the correct alternative for the following*

- (i) Consider the following declaration for a two-dimensional array in C: `char a[100][100];`  
Assuming that the main memory is byte addressable and that the array is stored starting from memory address 0, the address of `a[40][50]` is  
(a) 4040                      (b) 4050                      (c) 5040                      (d) 5050
- (ii) Given a pointer to the first node of a singly linked list, which of the following operation can be implemented in  $O(1)$  time?  
I) Insertion at the front of the linked list  
II) Insertion at the end of the linked list  
III) Deletion of the front node of the linked list  
IV) Deletion of the last node of the linked list  
(a) I and II                      (b) I and III                      (c) I, II and III                      (d) I, II and IV
- (iii) What will be the time complexity of insertion sort implemented on a singly linked list?  
(a)  $O(n \log n)$                       (b)  $O(n^2)$                       (c)  $O(\log n)$                       (d)  $O(n^3)$
- (iv) What is the minimum number of stacks needed to implement a queue? Consider the situation where no other data structure like arrays, linked list is available to you.  
(a) 1                      (b) 2                      (c) 3                      (d) 4
- (v) The best data structure to check whether an arithmetic expression has balanced parenthesis is  
(a) Stack                      (b) Queue                      (c) Tree                      (d) Array
- (vi) Which rotation is done when a new node is inserted in the right sub-tree of the right sub-tree of the critical node?  
(a) LL                      (b) LR                      (c) RR                      (d) RL

- (vii) The inorder and preorder traversal of a tree are (D,B,A,E,C) and (A,B,D,C,E) respectively. Then the leaf nodes of the tree are \_\_\_\_\_.  
 (a) C, D, and E      (b) C and E      (c) D and E      (d) E
- (viii) In a binary search tree (BST), what is the time complexity of searching for an element in the worst case?  
 (a)  $O(1)$       (b)  $O(\log n)$       (c)  $O(n)$       (d)  $O(n \log n)$
- (ix) A hash function  $f$  defined as  $f(\text{key}) = \text{key} \bmod 7$ , with linear probing used to resolve collisions. Insert the keys 37, 38, 72, 48, 98 and 11 into the table indexed from 0 to 6. What will be the location of 11?  
 (a) 3      (b) 4      (c) 5      (d) 6
- (x) Linked lists are not a suitable data structure for which of the following problems?  
 (a) Insertion sort      (b) Radix sort  
 (c) Binary Search      (d) Bubble sort.

*Fill in the blanks with the correct word*

- (xi) Any connected graph of  $x$  vertices has at least \_\_\_\_\_ edges.
- (xii) A binary tree with 27 nodes has \_\_\_\_\_ null branches.
- (xiii) \_\_\_\_\_ number of buckets needed to sort a list of strings only containing upper case alphabets using radix sort.
- (xiv) If a node having two children is deleted from a binary tree, it is replaced by its \_\_\_\_\_.
- (xv) \_\_\_\_\_ data structure is used for DFS.

### Group - B

2. (a) What do you mean by Linear and Non-Linear Data Structures. [[CO1](Remember/LOCQ)]  
 (b) If an array is declared as `float ar[5][6]`; in a C program and its base address is at 3040; find out the address of the element `ar[3][4]`. [[CO2](Analyze/IOCQ)]  
 (c) Write an algorithm to transpose a matrix represented in sparse form. Describe all assumptions that you will need to perform this operation. [[CO2](Apply/IOCQ)]  
**3 + 3 + 6 = 12**
3. (a) Compare between array and linked list. [[CO3](Analyse/HOCQ)]  
 (b) Write an algorithm to count the number of nodes in a singly linked list. [[CO2](Apply/IOCQ)]  
 (c) Write an algorithm to reverse a circular linked list [[CO2](Apply/IOCQ)]  
**4 + 3 + 5 = 12**

### Group - C

4. (a) Write an algorithm to convert an infix expression into an equivalent postfix expression. [[CO2](Apply/IOCQ)]  
 (b) What is input restricted de-queue? Explain with example. [[CO2](Remember/LOCQ)]

(c) What is tail recursion? Give example. [[CO2](Remember/LOCQ)]  
6 + (2 + 2) + 2 = 12

5. (a) State the Towers of Hanoi problem. Devise a solution to the Towers of Hanoi problem clearly explaining the pre-condition and post-condition for any algorithm you write. [[CO2](Analyse/IOCQ)]
- (b) What is priority queue? [[CO2](Remember/LOCQ)]
- (c) A single array A[MAXSIZE] is used to implement three stacks growing from different positions. Write the condition to check whether the stacks are full. Justify. [[CO2](Apply/IOCQ)]  
(2 + 4) + 2 + 4 = 12

### Group - D

6. (a) What are two ways of representing binary trees in the memory? Which one do you prefer and why? [[CO2](Understand/LOCQ)]
- (b) Given a binary tree whose inorder and preorder traversals are given by  
Inorder: E I C F B G D J H K  
Preorder: B C E I F D G H J K  
Draw the tree. What will be the post order traversal of the binary tree? [[CO2](Apply/IOCQ)]
- (c) In a full binary tree of height k, how many internal nodes are present? [[CO2](Analyse/IOCQ)]  
(2 + 2) + 5 + 3 = 12
7. (a) Write Kruskal's Algorithm for obtaining the minimum spanning tree from a given weighted graph. [[CO4](Remember/LOCQ)]
- (b) Construct a minimum spanning tree of the following graph using Kruskal's algorithm. Let the Starting vertex be D.

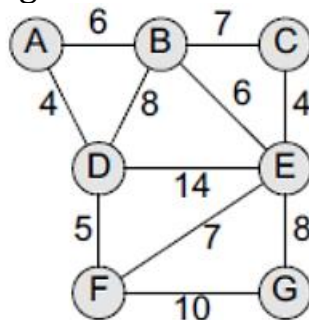

[[CO4](Apply/IOCQ)]  
6 + 6 = 12

### Group - E

8. (a) What is the best-case time complexity of Bubble Sort? Can we improve the performance of bubble sort? If yes, how? [[CO5](Analyse/IOCQ)]
- (b) Using the following dataset explain how merge sort can be applied to sort numbers in descending order.  
56, 258, 8, 95, 50, 64, 56, 11, 61 [[CO5](Apply/IOCQ)]  
(1 + 5) + 6 = 12

9. (a) What is the advantage of applying hashing? What are the characteristics of a good hash function? *[(CO6)(Remember/LOCQ)]*
- (b) Trace the action of radix sort on the following list of seven numbers considered as three-digit integers: 375, 447, 467, 395, 293, 235, 334. *[(CO5)(Apply/IOCQ)]*
- (2 + 4) + 6 = 12**
- 

Cognition Level	LOCQ	IOCQ	HOCQ
Percentage distribution	28.13	67.70	4.17