

FUNDAMENTALS OF SENSORS & TRANSDUCERS
(AEI3122)

Time Allotted : 2½ hrs

Full Marks : 60

Figures out of the right margin indicate full marks.

Candidates are required to answer Group A and any 4 (four) from Group B to E, taking one from each group.

Candidates are required to give answer in their own words as far as practicable.

Group – A

1. Answer any twelve:

12 × 1 = 12

Choose the correct alternative for the following

- (i) Potentiometric transducers work based on:
(a) Change in inductance (b) Change in capacitance
(c) Change in resistance (d) Change in frequency
- (ii) The gauge factor in a strain gauge is given by:
(a) $(\Delta R/R)/(\Delta L/L)$ (b) $(\Delta L/L)/(\Delta R/R)$
(c) $R \times L$ (d) L/R
- (iii) Working of capacitive microphone is based on change in
(a) Distance between plates (b) Dielectric medium
(c) Overlapping area between plates (d) None of these
- (iv) Charge sensitivity of a piezoelectric transducer is not zero in
(a) X-direction (b) Y- direction
(c) Z-direction (d) None of these
- (v) Ultrasonic transducer uses sound frequency
(a) Below 20 Hz (b) Between 20 Hz to 10 kHz
(c) Between 10 kHz to 20 kHz (d) Above 20 kHz
- (vi) Which of the following is an active sensor?
(a) RTD (b) Thermocouple
(c) Thermistor (d) AD590
- (vii) Which type of Thermocouple has the maximum sensitivity?
(a) T-type (b) K-Type (c) E-Type (d) J-Type
- (viii) Working principle of radiation pyrometer is based on the
(a) Wien's law (b) Kirchhoff's law
(c) Stefan-Boltzmann law (d) Seebeck effect

- (ix) Operation of photovoltaic cell is confined in which quadrant of the diode V-I characteristics?
 (a) 1st (b) 2nd (c) 3rd (d) 4th
- (x) Which one of the following materials would be used for making an LDR?
 (a) Lead Sulphide (b) Pure Aluminium
 (c) Iron Ore (d) Aluminium Oxide

Fill in the blanks with the correct word

- (xi) The loading effect in a potentiometric transducer occurs when the resistance of the load is _____ compared to the transducer.
- (xii) The sensitivity of a parallel plate capacitive transducer _____ with increase in dielectric constant.
- (xiii) Cold junction compensation in thermocouples helps to correct errors due to _____ variations.
- (xiv) Optical radiation pyrometer primarily detect _____ radiation.
- (xv) Photoconductors are the devices whose _____ changes with change in light intensity.

Group - B

2. (a) Define reproducibility and Fidelity. [[CO1](Remember/LOCQ)]
 (b) The voltmeter shown in the figure has a sensitivity of $500 \Omega/V$ and a full scale of 100V. When connected in the circuit as shown, the meter reads 20 V. Find the value of R_x ? [[CO1](Apply/IOCQ)]

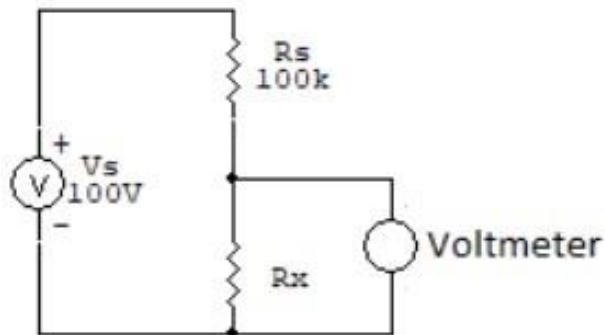

- (c) Define gauge factor. [[CO2](Remember/LOCQ)]
 (d) A strain gauge has a nominal resistance of 600Ω and a gauge factor of 2.5. The strain gauge is connected in a d.c. bridge with three other resistances of 600Ω each. The bridge is excited by a 4 volt battery. If the strain gauge is subjected to a strain of $100 \mu m/m$, find the magnitude of bridge output. [[CO2](Analyse/IOCQ)]
 $2 + 5 + (2 + 3) = 12$
3. (a) How LVDT can be used to measure both pressure above and below the atmospheric pressure? [[CO3](Analyse/IOCQ)]
 (b) What is residual voltage? State the causes of residual voltage appeared in LVDT. [[CO2](Analyse/IOCQ)]

- (c) Describe the input-output characteristics of LVDT. [[CO2](Understand/LOCQ)]
4 + (1 + 2) + 5 = 12

Group - C

4. (a) Explain principle of working of a capacitive transducer that can be used to measure displacement by changing position of dielectric. Hence show that change in capacitance is function of displacement of the dielectric. [[CO3](Analyse/IOCQ)]
(b) Draw a circuit that can be used to measure the change in capacitance. [[CO3](Analyse/IOCQ)]
(c) Define piezoelectric effect and state two materials show the piezoelectric effect. [[CO2](Remember/LOCQ)]
(2 + 3) + 3 + (2 + 2) = 12
5. (a) What is the static sensitivity of piezoelectric transducer? How that can be tolerated? Explain the scheme to measure static force using piezoelectric transducer. [[CO3](Apply/IOCQ)]
(b) What do you mean by ultrasound? State two applications of ultrasonic transducer. [[CO3](Remember/LOCQ)]
(c) Draw the levelled schematic of an ultrasonic transducer. [[CO5](Apply/IOCQ)]
(1 + 1 + 4) + (1 + 2) + 3 = 12

Group - D

6. (a) What is a thermocouple? What is meant by cold junction compensation? Why is it necessary? A thermocouple with reference junction temperature at 20°C gives an output of 5 mV. If the thermocouple sensitivity is 50µV/°C, then calculate the measured temperature. [[CO4](Understand/LOCQ)]
(b) What is a thermopile? Explain with a suitable electrical circuit how one can measure an average temperature of a reaction column using thermocouples. [[CO4](Analyse/IOCQ)]
(1 + 2 + 2 + 2) + (2 + 3) = 12
7. (a) Which temperature sensor is best for keeping an eye on the motherboard or CPU temperature? State two features of the sensor you mentioned. [[CO4](Remember/LOCQ)]
(b) Explain operation of total radiation pyrometer with suitable schematic diagram. [[CO4](Analyse/IOCQ)]
(c) A semiconductor sensor has a sensitivity of 10 mV/°C. If the sensor output is 0.75V, determine the corresponding temperature. [[CO2](Analyse/IOCQ)]
(d) State the material composition of any one base metal type and one noble metal type thermocouple. [[CO2](Remember/LOCQ)]
(1 + 2) + 5 + 2 + 2 = 12

Group - E

8. (a) Define a smart sensor. Explain its basic working principle with suitable block diagram. [[CO6](Understand/LOCQ)]

- (b) Draw and explain the architecture of MEMS device. [[CO6](Understand/LOCQ)]
- (c) State any two advantages and two applications of smart sensors. [[CO6](Remember/LOCQ)]
- 4 + 4 + 4 = 12**
9. (a) Describe working of a LED with necessary schematic diagram. Hence draw the characteristics of LED. [[CO2](Analyse/IOCQ)]
- (b) State the features of smart sensor with necessary explanation. [[CO6](Remember/LOCQ)]
- (c) State the working of bi-colour LED. [[CO2](Apply/IOCQ)]
- (4 + 2) + 4 + 2 = 12**
-

Cognition Level	LOCQ	IOCQ	HOCQ
Percentage distribution	48.96	51.04	0